

EMX 14.0.4.8

What's New?



Enhancement

- Improve the Extract fluid circuit functionality
 1. Improve algorithm to detect related fluid bores
 2. Implement new radio group with option to assemble a subassembly for fixed and moving half, but also a part for each cooling circuit
 3. Use progress bar to avoid freezing of Creo window

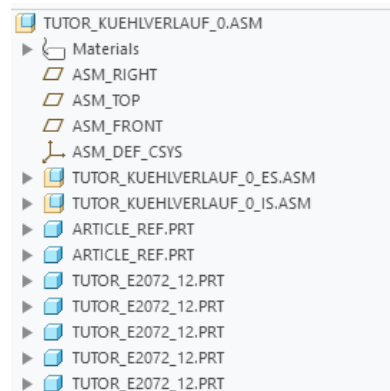
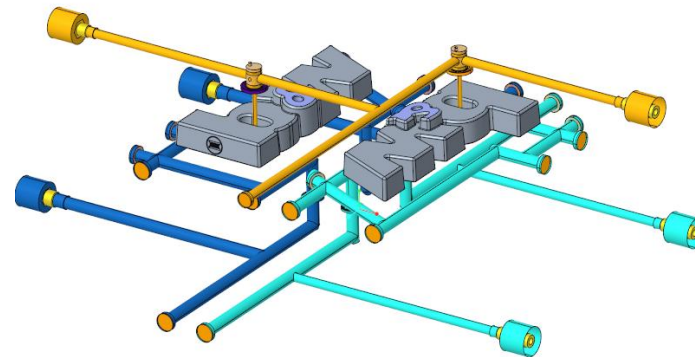
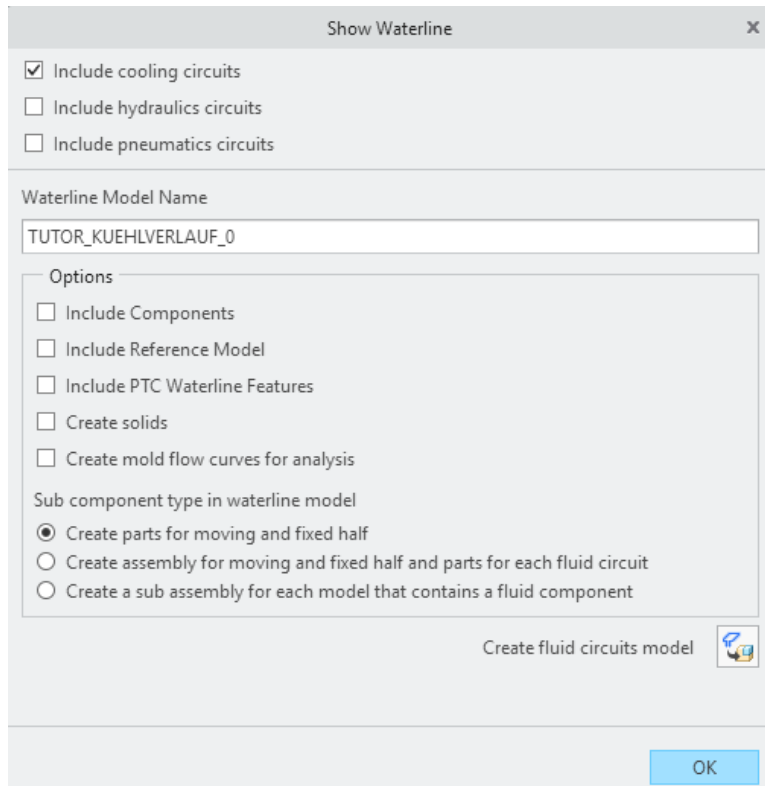

Enhancement

- Implement solution to directly use measured values from Tiny Measure Tools in nominal values of component dialog
 - Select dimension in nominal values table
 - Open Tiny Measure Tools with Right Mouse Click
 - Measure diameter, length or offset
 - Best fit value will be used in nominal value table

Dimension Name	Value	Type
DM1 - Diameter	0.4	
LG - Length	100	
OFFSET - Offset	0	
REF_ANGLE - Angle	0	
REF1 - Reference Dista	56.000	

EMX Question

Measured diameter: 4.500
The best fit value in the option menu is: 4.5

Use the best fit result in nominal value?

Dimension Name	Value	Type
DM1 - Diameter	4.5	
LG - Length	100	
OFFSET - Offset	0	
REF_ANGLE - Angle	0	
REF1 - Reference Dista	56.000	

Enhancement

- Update SmartHolechart to Version 14.0.1.6
- New Components Meusburger Guide E1332 and E1146
- Implement new cooling O-rings from new suppliers Hagenauer and Arcus
- Add Ermanno Balzi cooling component TR, TRI, RF, RFP, RL, RLS

EMX 14.0.4.7

What's New?

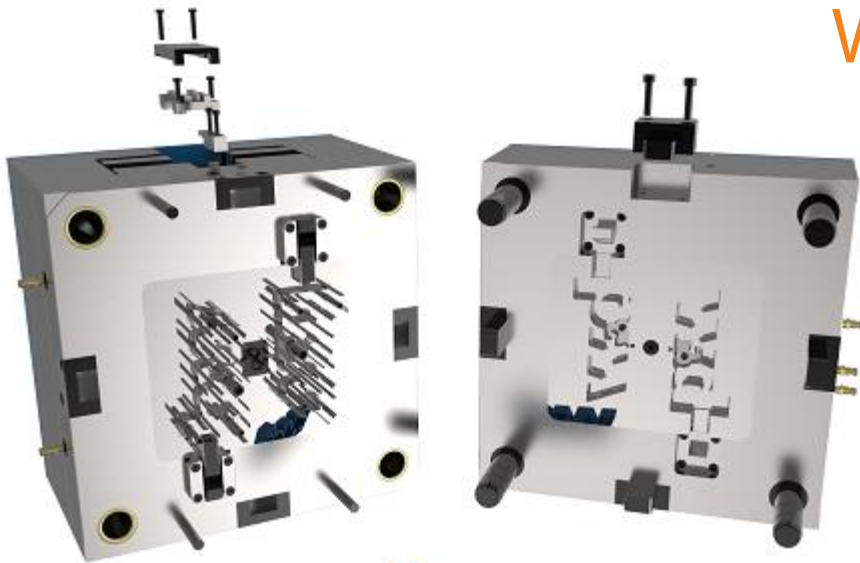

Enhancement

New HASCO cooling components:

- Z87: Hose Nipple
- Z87VA: Hose Nipple, stainless steel
- Z9425: Sealing plug with O-Ring
- Z9425VA: Sealing plug with O-Ring, stainless steel
- ZI81: Hose Nipple, Open Flow, USA

Enhancement

- Implement new config option BOM_ALLOW_EDIT_PROJECT_PARAMS to allow manual editing of project parameters in BOM

Default Value is: NO

Behavior NO:

- Project parameters are disabled in Bill of Materials List.
- Value can not be edited
- Value is always overwritten from top assembly

Behavior YES:

- Project parameter can be edited in Bill of Materials
 - Value needs to be unlocked in BOM
- 
- Decorative curved lines in the bottom right corner, consisting of a thick grey curve and a thin orange curve.

EMX 14.0.4.6

What's New?

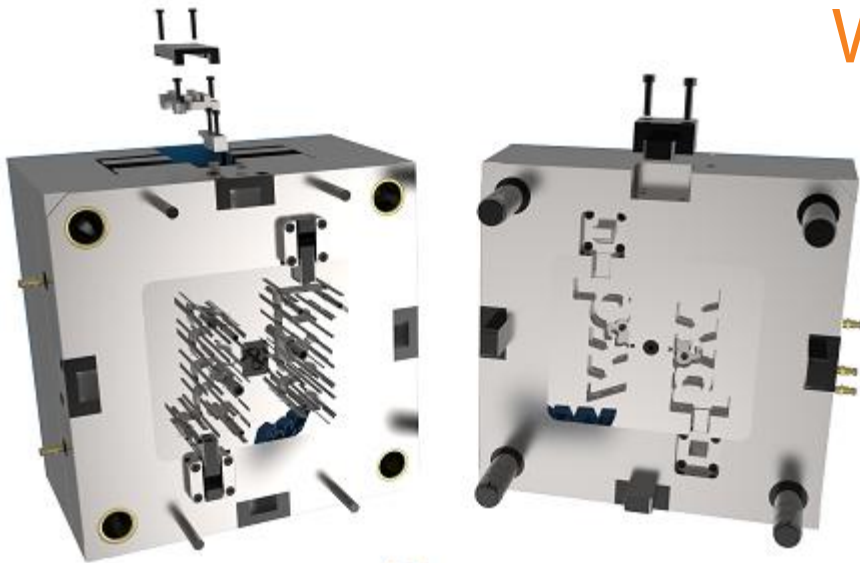

Enhancement

- Introduce functionality to save configuration to current session only. “Current Session” can be selected in Options Dialog from option menu

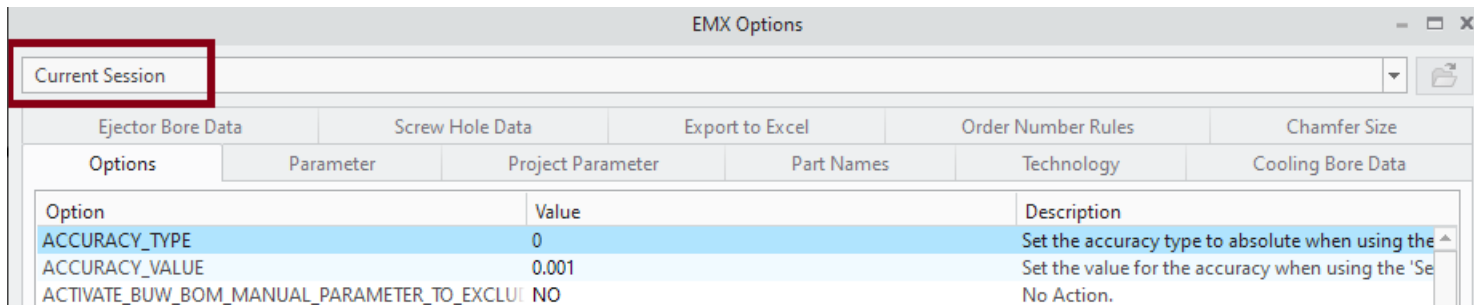

- Several minor fixes and internal improvements

EMX 14.0.4.5

What's New?

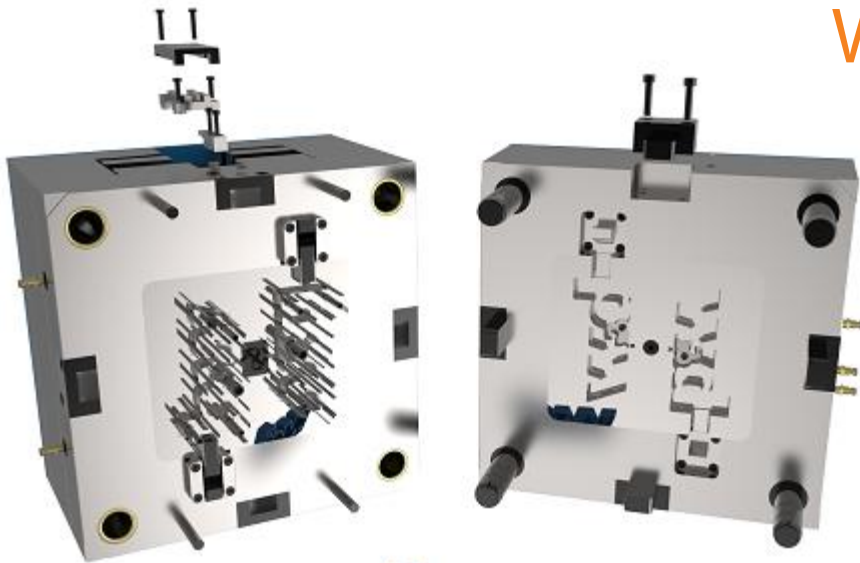

Enhancement

- Update Smart Holechart to Version 14.0.1.5
- Allow flexible items for guide components
- Several minor fixes and internal improvements

EMX 14.0.4.3

What's New?

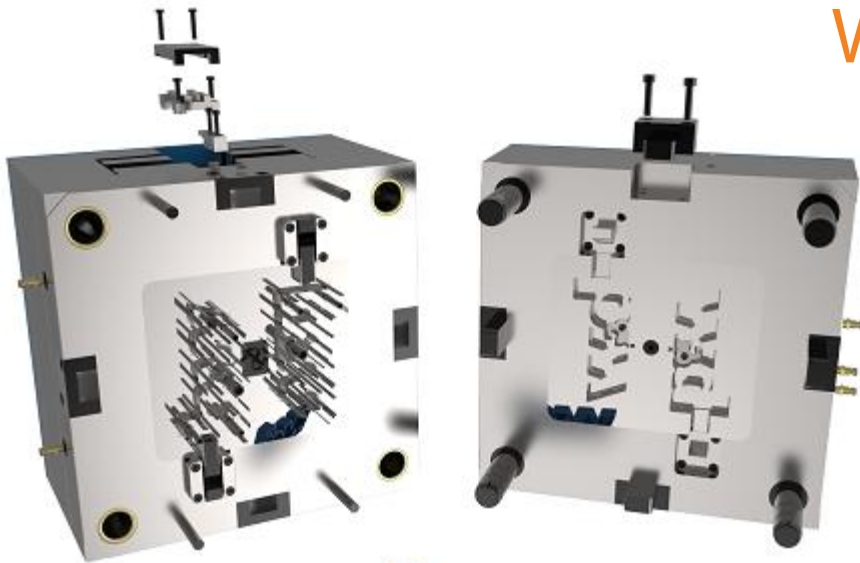

Enhancement

- Update existing MEUSBURGER components to state April 2024
- Enhancements for Engraved Texts for ejector pins:
 - New Options EJP_ENGRAVED_TEXT_TYPE: Sketch can be created as contour or middle line.
 - Parameter defined in PARAM_EJP_ENGRAVED_TEXT will only be created at ejector pin models.

EMX 14.0.4.0

What's New?

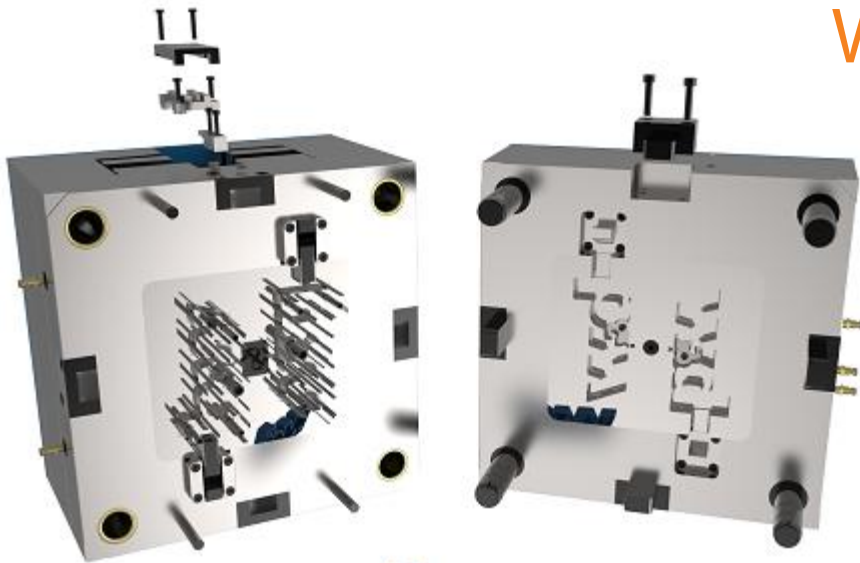

Enhancement

- Update SmartHolechart to version 14.0.1.4

EMX 14.0.3.11

What's New?

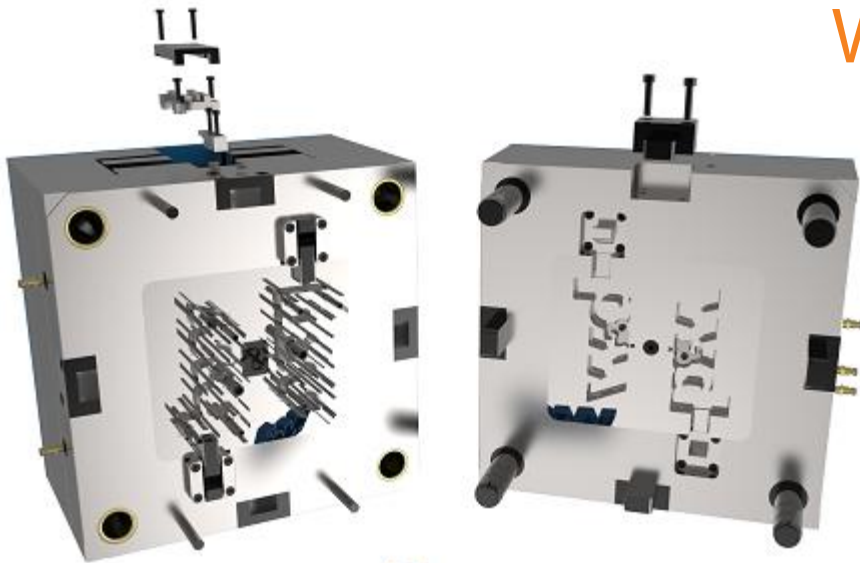

Enhancement

New Feature: Assemble engraved texts for Ejector Pins

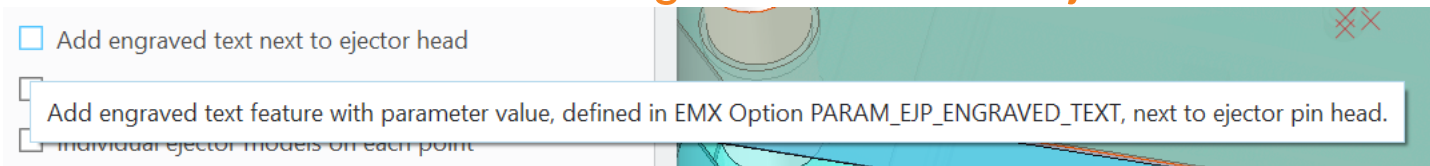

- New Option in Ejector Dialog: *Add engraved text next to ejector head*
- Text feature will be created in ejector model on head surface and next to head cutout UDF in plate.
- Text is controlled by relation and driven by a part parameter
- Part parameter must be defined with new Configuration Option *PARAM_EJP_ENGRAVED_TEXT* otherwise option in ejector dialog is disabled.
- New config file: *engraved_text_heights.cfg* to define valid text heights



Enhancement

- Update existing HASCO components to state April 2024
- Update existing KNARR components to state April 2024
- Improve performance of additional chamfer creation in case of multiple point features.

EMX 14.0.3.10

What's New?

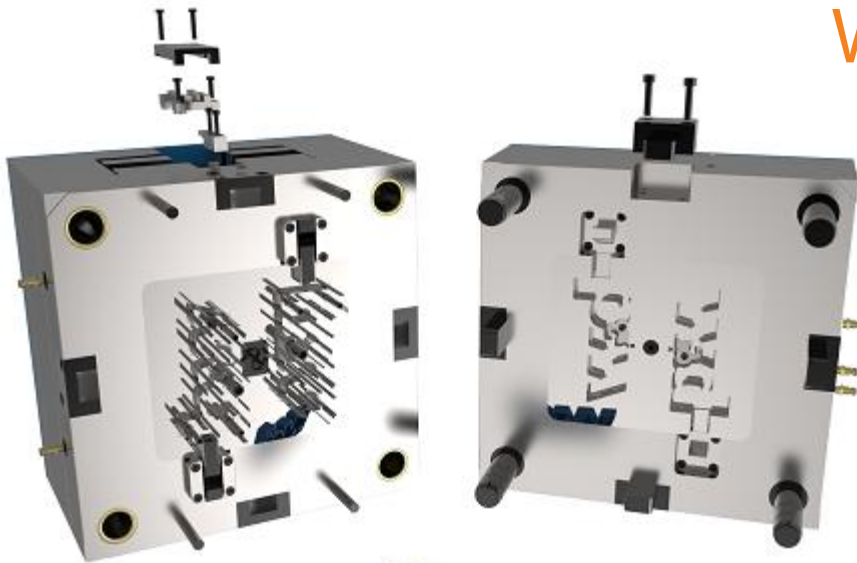

Enhancement

- Update existing Meusburger components to state January 2024

EMX 14.0.3.9

What's New?

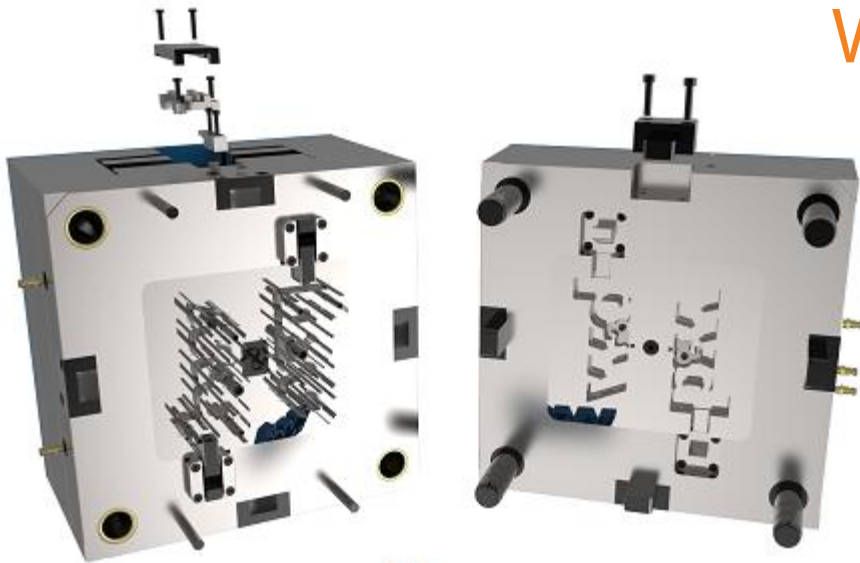

Enhancement

- New Stäubli CBX and CBI connectors for Hydraulics
- Improved Stäubli RMI and CBI connectors in cooling
- Overall improved functionality: Selectable option sealing and BF

- New Knarr Eyebolt screw 40811

EMX 14.0.3.8

What's New?

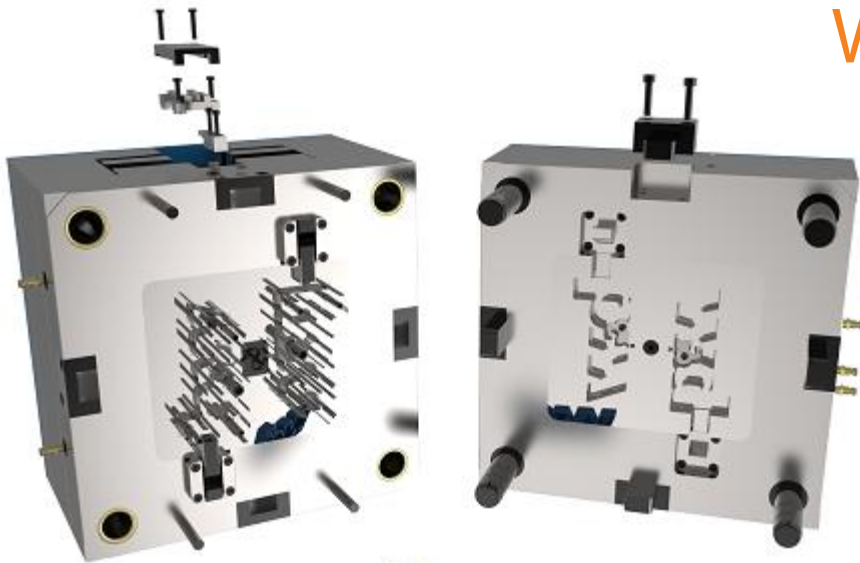

Enhancement

- New HASCO components:
 - Guide component: Z1300
 - Ejector Pins: DLC shouldered Z4430, cylindrical air-ventilated pin Z401
 - Top Interlocks: Cubic interlocks Z060 and Z080, spacer plate Z081.
 - Side Interlocks: Z085.
 - Attachment components: Flange Z167, Cycle Counters A5730, A5730HT, A57300, A57300HT, A5731, A5732
- Existing HASCO components updated to state of Summer 2023

Enhancement

- Component Editor: Enhanced functionality to edit subcomponent instances
 → Library Assemblies can be now fully defined in Component Editor.

Component Editor

BOM Data Assembly References Instances Nominal Dimensions Options Features UDFs Subcomponents

Subcomponents SIDEITLK_E1308

Type				SCR_LENGTH	SCR_DIA	Instances
1	SIDEITLK_E1308	SIDEITLK_E1308	1	SIDEITLK_E13082	6	3
2	SIDEITLK_E1308	46			12	6
3	SIDEITLK_E1308	50	E13081_50	E13082_50	16	6
4	SIDEITLK_E1308	60	E13081_60	E13082_60	20	8
5	SIDEITLK_E1308	76	E13081_76	E13082_70	25	8

Select subcomponent to edit instances

In case subcomponents exists selected from option menu.

EMX 14.0.3.6

What's New?

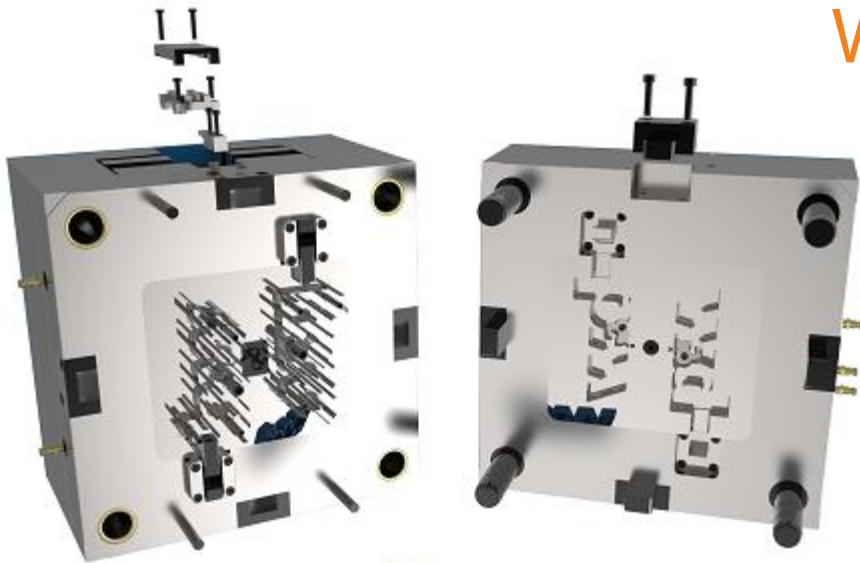

Enhancement

- Meusburger components updated to Status July 2023
- Diverse issues solved

EMX 14.0.3.4

What's New?

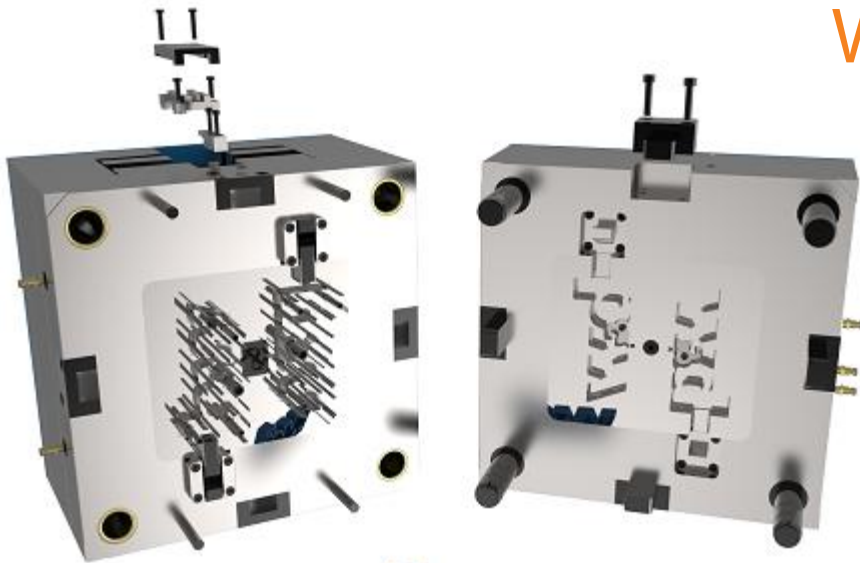

Enhancement

- New Component Type: **Electronic Components**
- **KNARR:** 807600, 807600-2, 807700, 807700-2, 807650, 808600, 808600-2, 808700, 808700-2, 808650, 807600-4, 808600-4
- **MEUSBURGER:** E6500, E65005, E6502, E65025, E6504, E6505, E65055, E6507, E65075, E6509
- **STRACK:** Z7600, Z7600-2, Z7600-4

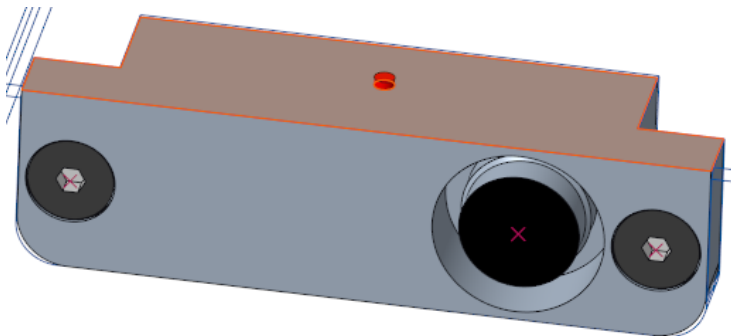
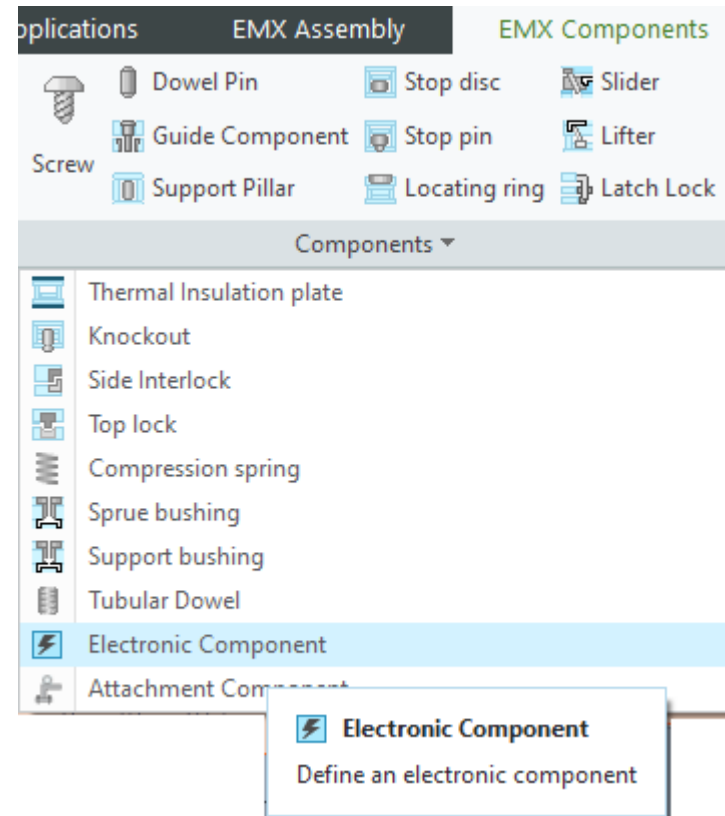

Enhancement

- New Component Type: **Attachment Components**
- **MEUSBURGER** limit switches:
E6500, E65005, E6502, E65025,
E6504, E6505
- **MEUSBURGER** transport bridge
E1930
- **OPTIZ** date stamps

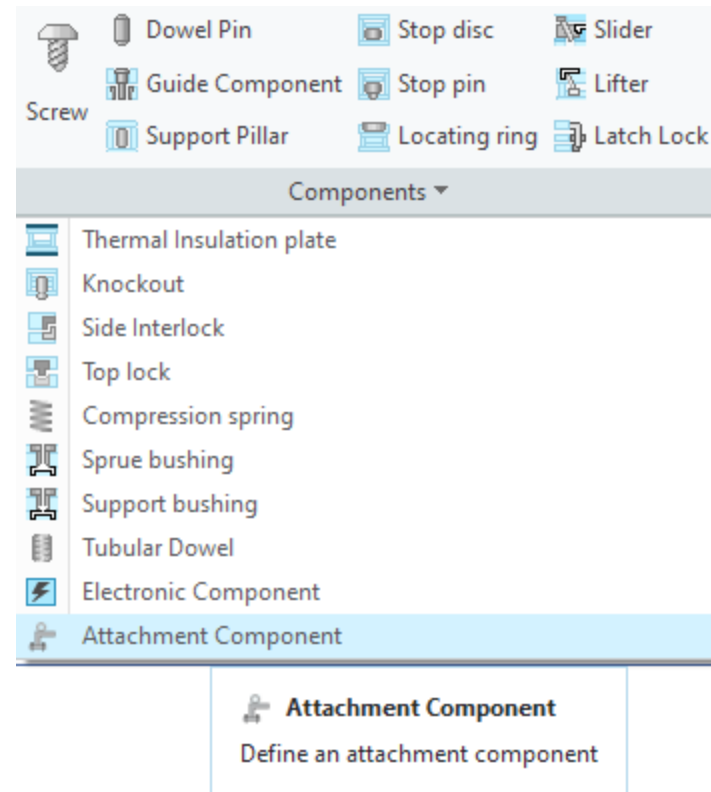
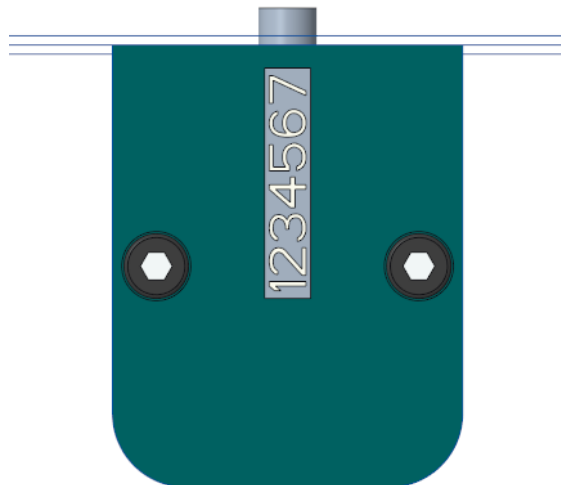

Enhancements

New components:

- New KNARR guide FreeLub 517404

EMX 14.0.3.1

What's New?

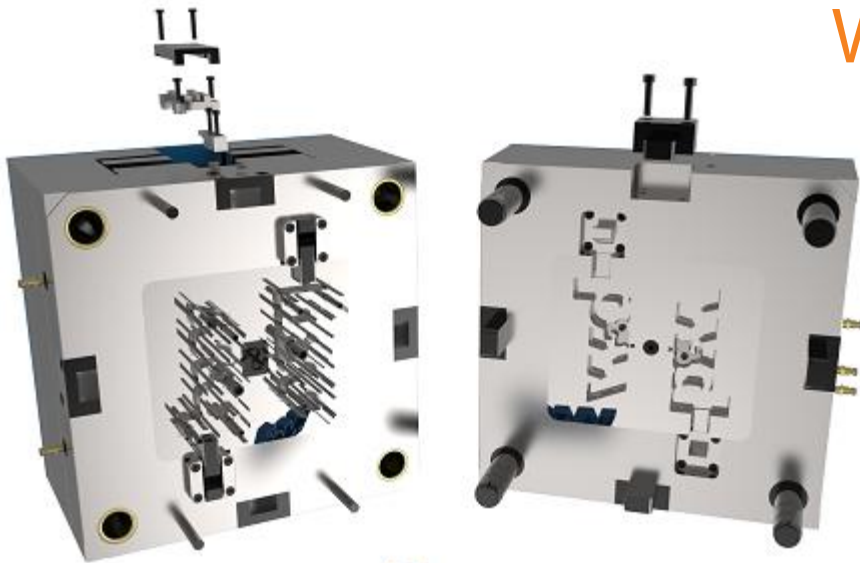

Enhancement

- New American Standard Sealing Rings for different assembly situations
- Components are assembled as flexible models.
 - Same model can be used in different assembly scenarios.
 - Model changes width based on compressed height without changing the volume of the sealing ring.
- Inner and outer pressure and coaxial scenarios are supported.

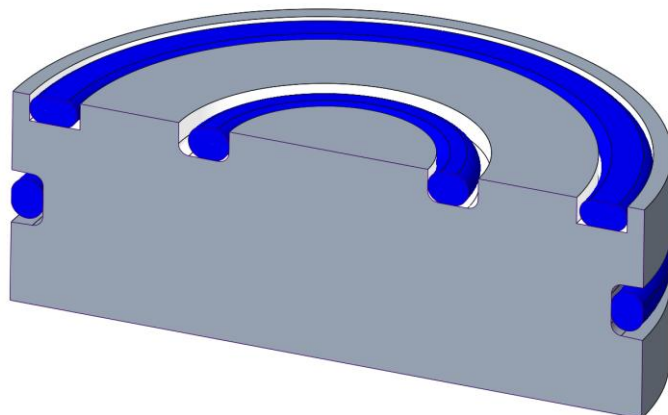

Cooling Component

Subassembly: 123

Unit: mm inch

Supplier: as

Type: AS568_AXIAL_FKM_75 | O-Ring

Dimension Name	Value	Type
DM2 - Diameter	1.78	
DM1 - Inner Diameter	1.78	
DM_FLEX - Mounting	5.287	
W_GROOVE - W_GROC	2.4	
T_GROOVE_FLEX - Gro	1.5	
DM_RESULT - Result Di	0.487	
OFFSET - Offset	0	

Part Name: 123_AS568_004_1_78_1_78

(1) Curve|Axis|Point (2) Surface

Component options: Circular Groove Add additional chamfers to edges

Draft Cut Without Core Bore

Define depth by: Use curve length

Na:	Value	Tolerances	Rule
D5	1.000		1
T5	0.000		AUTO_DEPTH
D1	5.287		DM_FLEX
T1	1.500		T_GROOVE_FLEX
D3	0.487		DM_FLEX-2*W_GROOV
A	59.000		59
TX	3.000		T_GROOVE_FLEX*2

OK Cancel

Improvements

- Improved “Trim” feature behavior for ejector pins
 - Improved “Auto Length” feature behavior for ejector pins
- Auto length feature is now created as additional feature in ejector model.
 - “Real” length of ejector model is untouched.
 - In Modify mode “Auto Length” and “Trim” feature can be unset again.

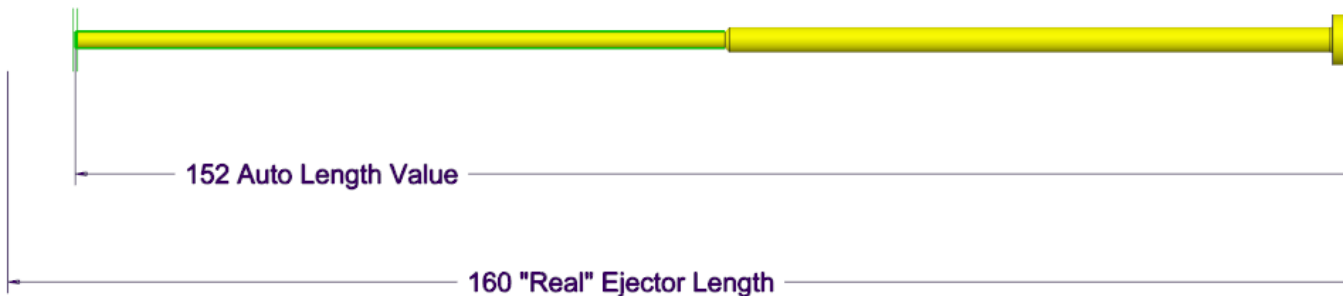
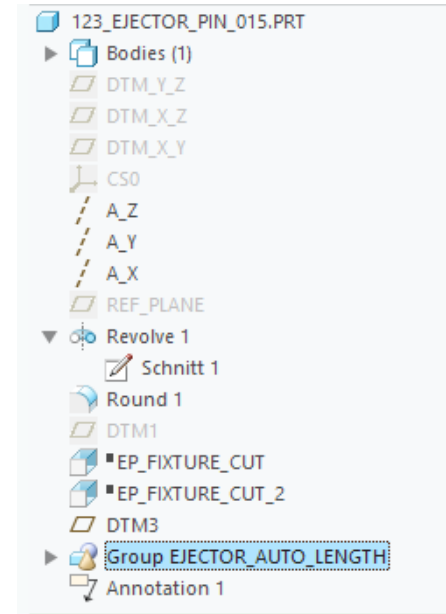

EMX 14.0.3.0

What's New?

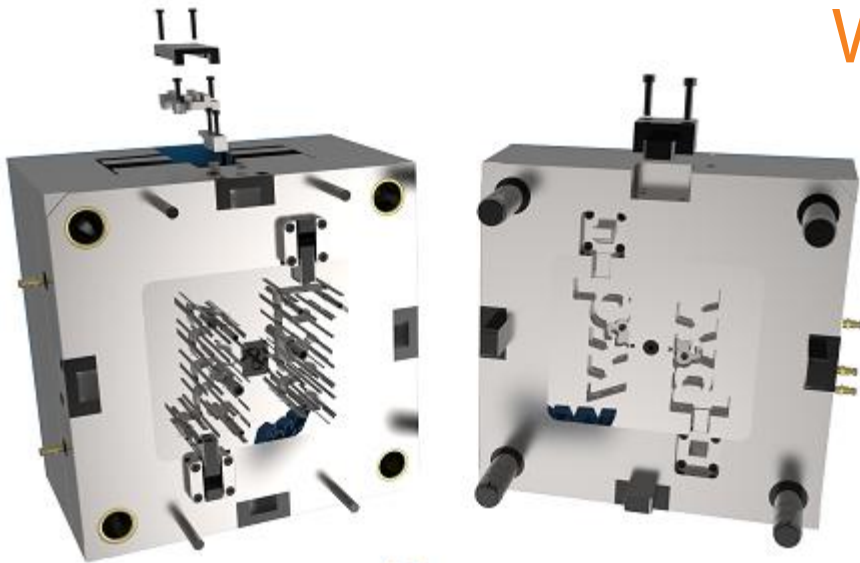

Improvements

- Add new Misumi guide components GPH and GPHL.

EMX 14.0.2.4

What's New?

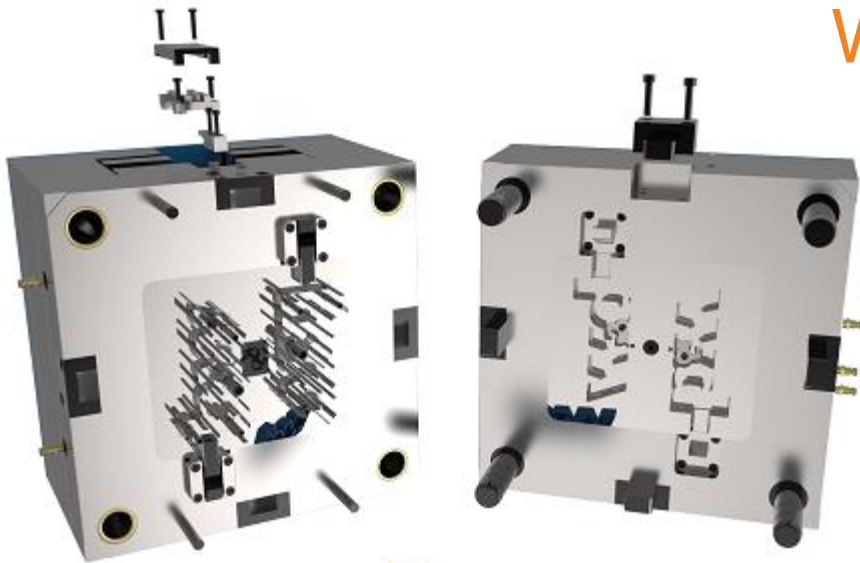

Improvements

- Improved Component Editor
 - Easily create part name rules for assemblies within dat files
 - Improved definition of instance dimensions with right mouse menu
 - etc.
- New config option EXCEL_TEMPALTE_PATH to set up default location for Bill of Material Excel template file

EMX 14.0.2.0

What's New?

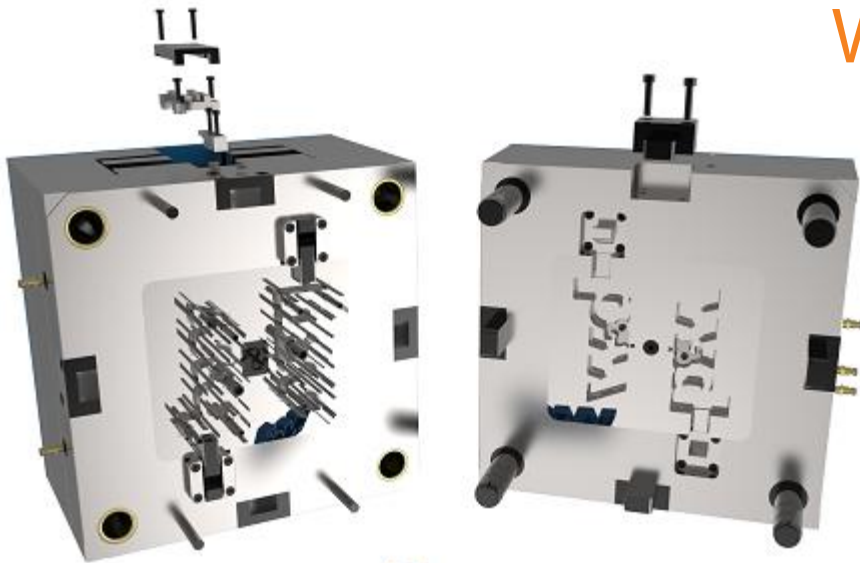

Enhancements

New STRACK Latch Lock Z3 and Z5 implemented:

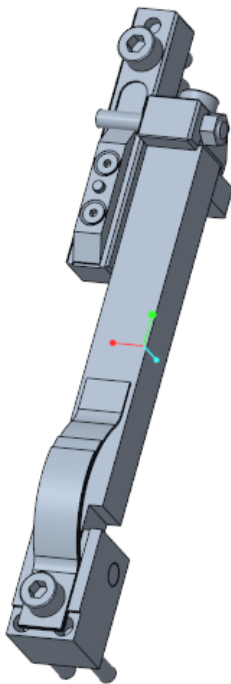

Z5 – 0/1/2

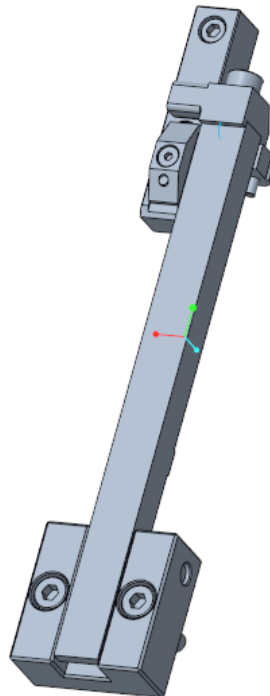

Z5 – 31/32



- Z3 – 1 / 2 / 3
- Z3 – 11 / 21 / 31

Enhancements

New STRACK Two Stage Ejector Z5085 implemented:

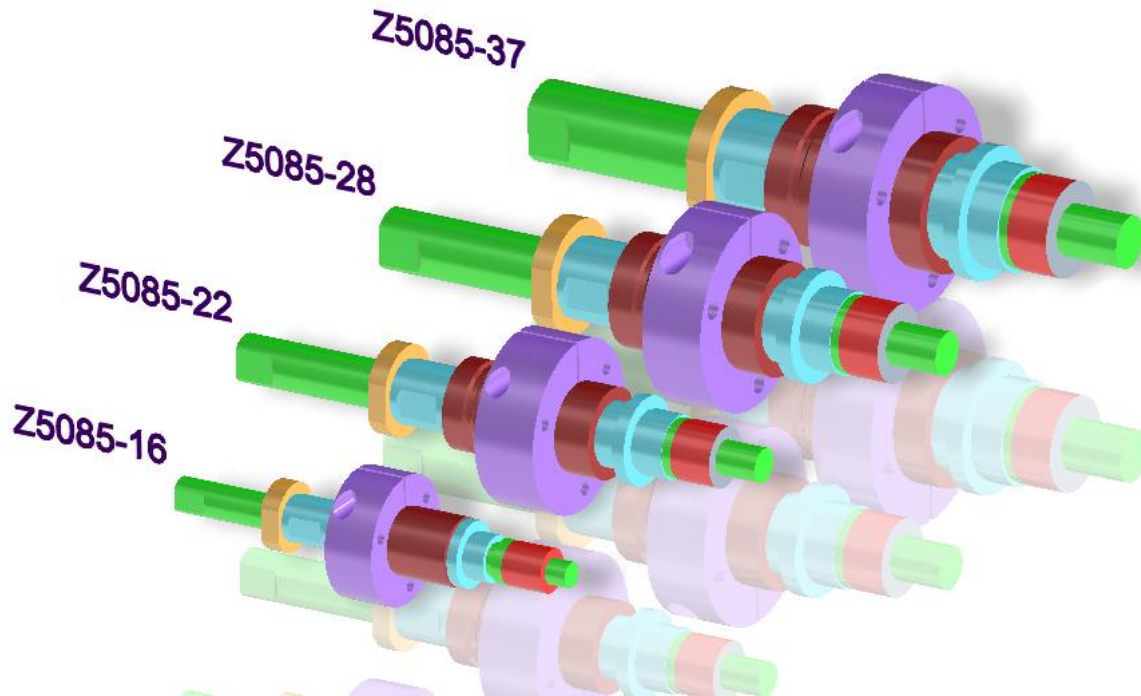

Enhancements

- Update KNARR plates F and K, ejector pins, screws, dowel pins, guides, insulation plates, knockouts, locating rings, stop discs to 2022 catalog status
- Allow <project_name>, <pre>, <post> placeholders in BOM_FILENAME option.

EMX 14.0.1.10

What's New?

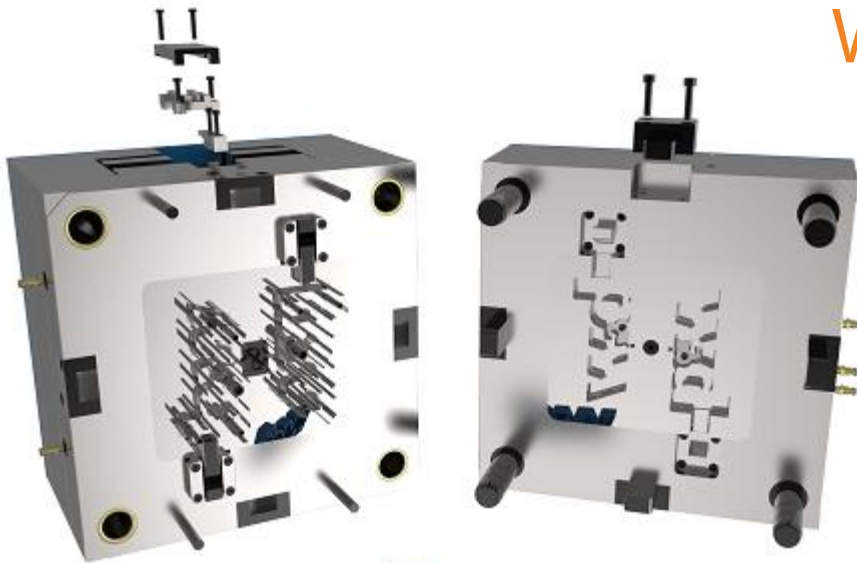

Enhancements

New components:

- New MEUSBURGER cooling components E20767, E20769 and E20809
 - New STRACK pneumatic components Z139 Z5144, Z5145 and Z5146
 - New STRACK slider holding device Z5129, Z5130, Z5131
 - New STRACK stroke cylinders Z5100, Z5101, Z5102
 - New STRACK thrust pieces Z3152, Z3154, Z3153, Z3156 and Z3158
 - New knockout STRACK Z5085
- 
- Decorative curved lines in the bottom right corner, consisting of a thick grey arc and a thin orange arc.

EMX 14.0.1.6

What's New?

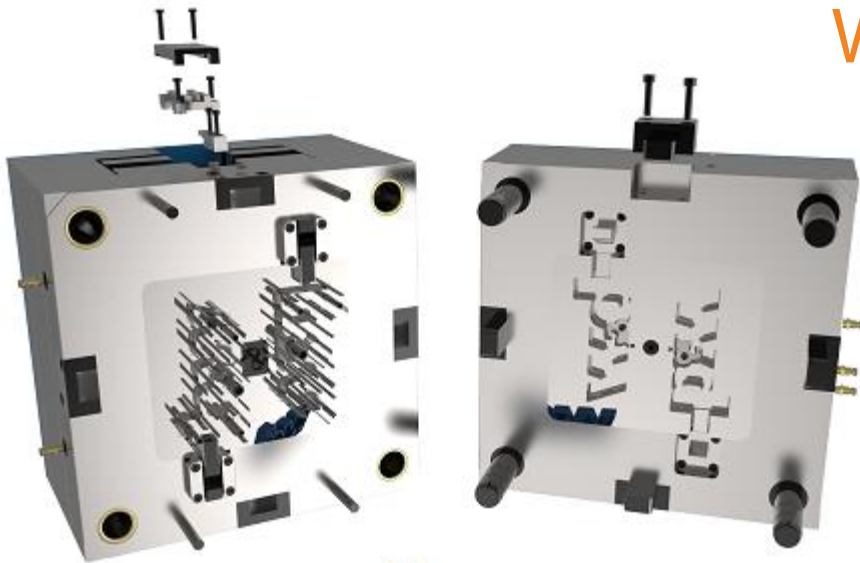

Enhancements

Improved MATERIAL_PATH behavior

- Materials can be structured in subfolders

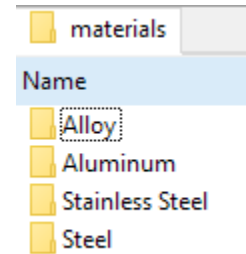

- Config Option MATFILE_EXTENSION is no longer active.
- *.mtl files are handled with higher priority than *.mat files
- Search priority is now:
 - Files from Material Path
 - *.mtl
 - *.mat
 - Files from USER_CONFIG_PATH
 - *.mtl
 - *.mat
 - Files from INSTALLATION
 - *.mtl
 - *.mat

EMX 14.0.1.5

What's New?

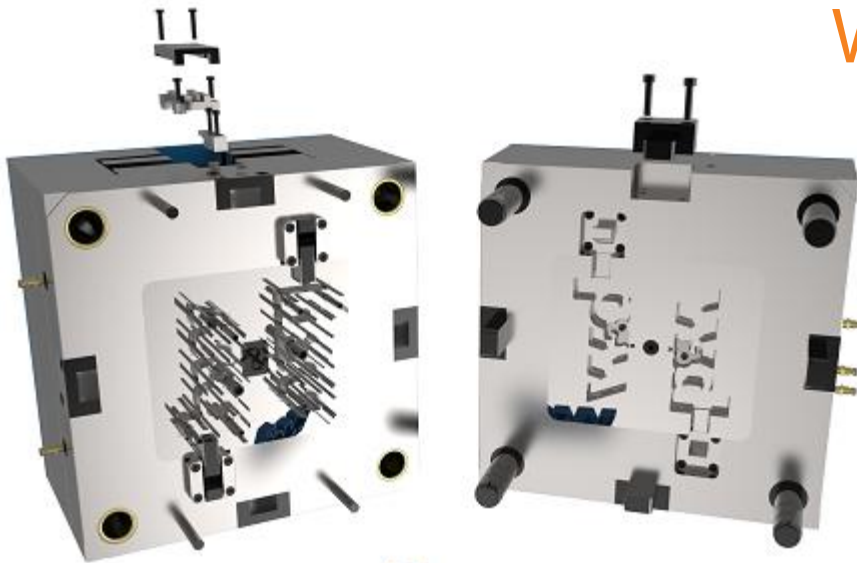

Enhancements

- New XML based recipe files

Deprecated text-based files still work

- New MEUSBURGER ejector pins

E1770 (with air ventilation), E1780, E17109

- New PEDROTTI guides

EBU2, EBU2B, EZP1H, EBU3B, EZP1

- New PEDROTTI ejector pins

EES2CB, EES2DLC, EES2NL, EES2CL_2RAD, EES2CL_4RAD

- Option “Force cutout in surface owner” removed for guides, ejectors and screw

Not required anymore due to improved cut out algorithm

A decorative graphic element consisting of a thick grey curved line and a thinner orange curved line, both curving upwards from the bottom right corner of the slide.

EMX 14.0.1.4

What's New?

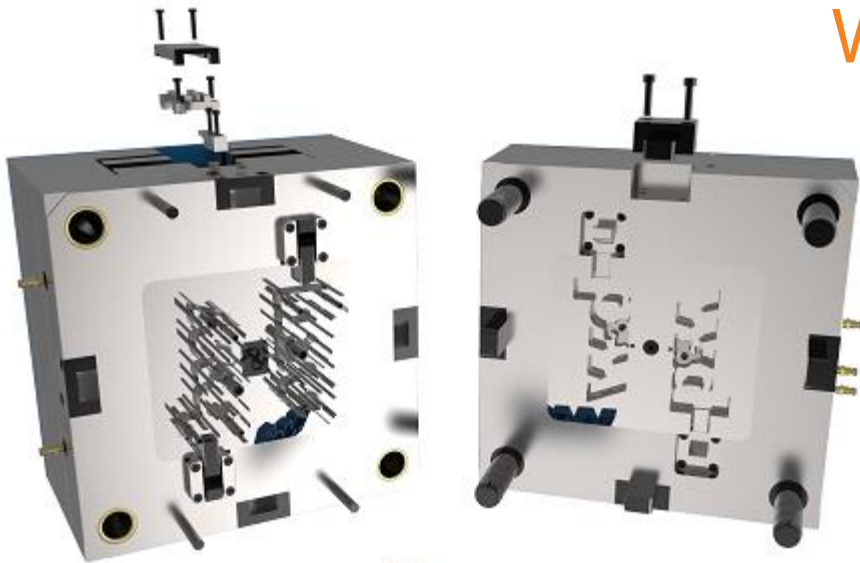

Enhancements

- New weblink button in Library Component Dialog
- New and updated PEDROTTI guide components

EBU1, EBU1B, EBU1BG, EBU1H, EBU1HBG, EBU1S, EBU1SBG, EBU1SH, EBU3, EBU3B, ECO1, ECO1H, ECO1S, ECO1SH, ECO2, ECO2E, ECO2L, ECO2LC, ECO2SG

EMX 14.0.1.1

What's New?

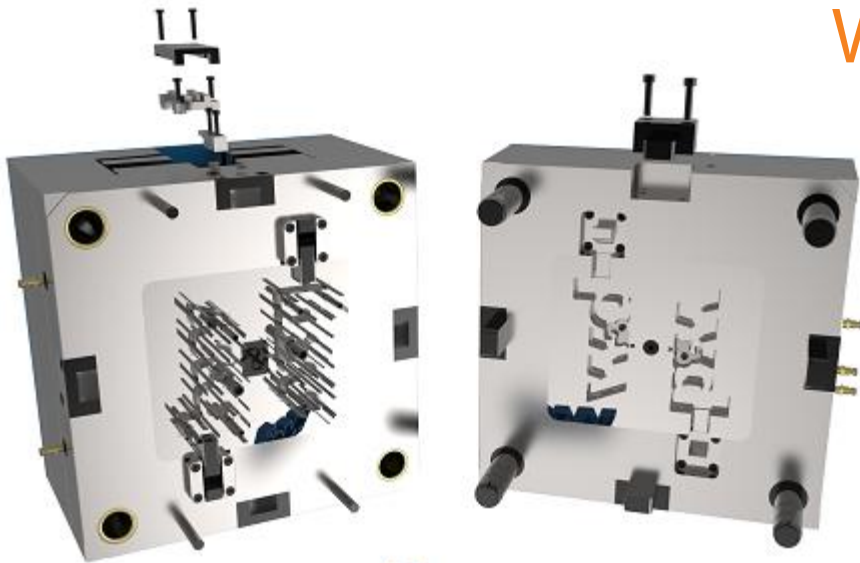

Enhancements

New Flexible Springs:

- Springs can now be assembled as flexible models.
- Implemented for Hasco, Meusburger and Strack springs.
- The same model can be assembled multiple times, but with different lengths

Dimension Name	Value	Type
DM2 - Diameter	19	
LG0 - Length	90	
DM1 - Inner Diameter	10	
Ln - Minimal length	73	
Fn - force	1669	
L_un - Length unload	90.000	
L_lo - Length loaded	73.000	
OFFSET - Offset	0	

F_{un} = 0.00
F_{lo} = 1669.00
S = 17.00

- ▶ Group EMX_REF_POINT_PLANE
- ▶ 123_SPRING_20.PRT
- ▶ Group EMX_REF_POINT_PLANE_1
- ▶ 123_SPRING_20.PRT

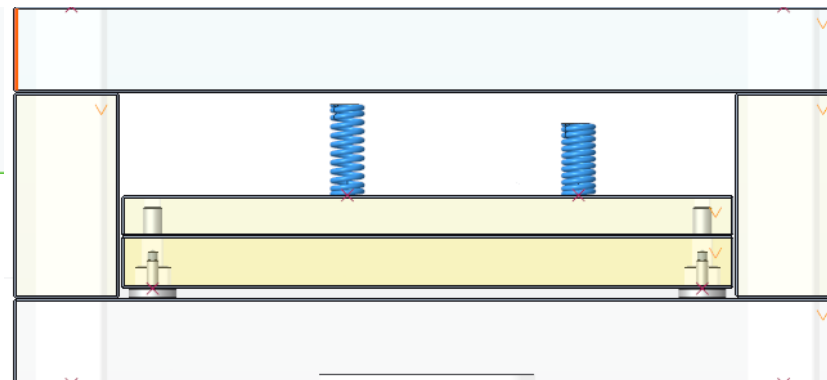

EMX 14.0.1.0

What's New?

