

EMX 15.0.3.10

What's New?

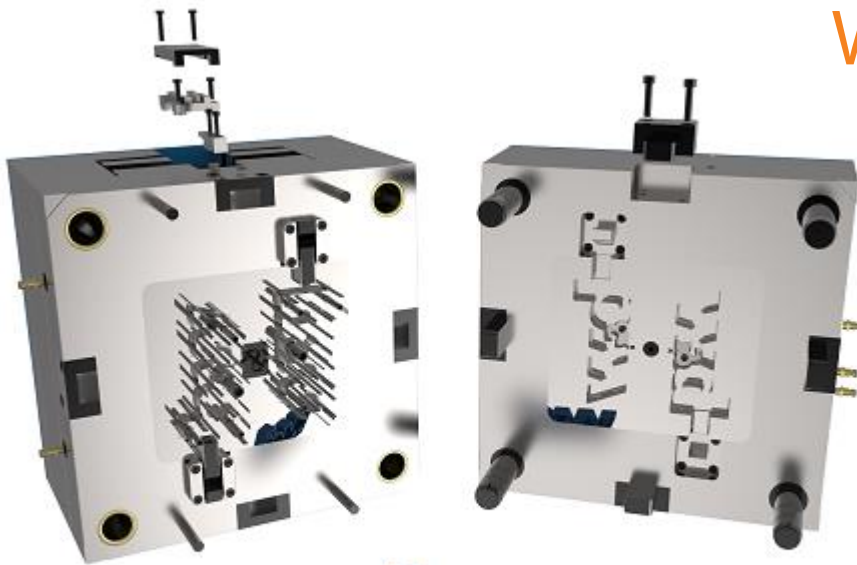

Enhancement

- New Stäubli CBX and CBI connectors for Hydraulics
- Improved Stäubli RMI and CBI connectors in cooling
- Overall improved functionality: Selectable option sealing and BF

- New Knarr Eyebolt screw 40811

EMX 15.0.3.9

What's New?

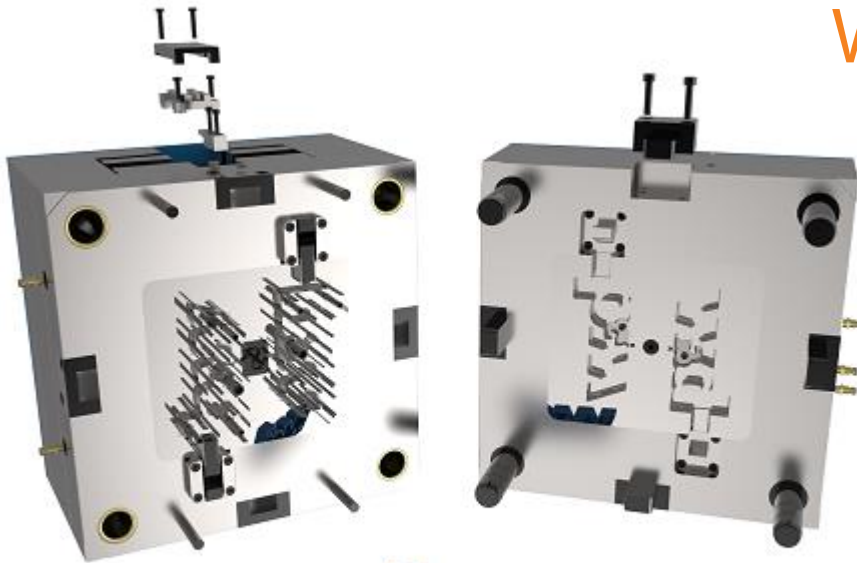

Enhancement

- New HASCO components:
 - Guide component: Z1300
 - Ejector Pins: DLC shouldered Z4430, cylindrical air-ventilated pin Z401
 - Top Interlocks: Cubic interlocks Z060 and Z080, spacer plate Z081.
 - Side Interlocks: Z085.
 - Attachment components: Flange Z167, Cycle Counters A5730, A5730HT, A57300, A57300HT, A5731, A5732
- Existing HASCO components updated to state of Summer 2023

Enhancement

- Component Editor: Enhanced functionality to edit subcomponent instances
 → Library Assemblies can be now fully defined in Component Editor.

Component Editor

BOM Data | Assembly References | **Instances** | Nominal Dimensions | Options | Features | UDFs | Subcomponents

Subcomponents: SIDEITLK_E1308

Type				SCR_LENGTH	SCR_DIA	Instances
1	SIDEITLK_E1308	SIDEITLK_E1308	1	SIDEITLK_E13082	6	E1308_40
2	SIDEITLK_E1308	46			12	E1308_46
3	SIDEITLK_E1308	50	E13081_50	E13082_50	16	E1308_50
4	SIDEITLK_E1308	60	E13081_60	E13082_60	20	E1308_60
5	SIDEITLK_E1308	76	E13081_76	E13082_70	25	E1308_76

Select subcomponent to edit instances

In case subcomponents exists selected from option menu.

EMX 15.0.3.6

What's New?

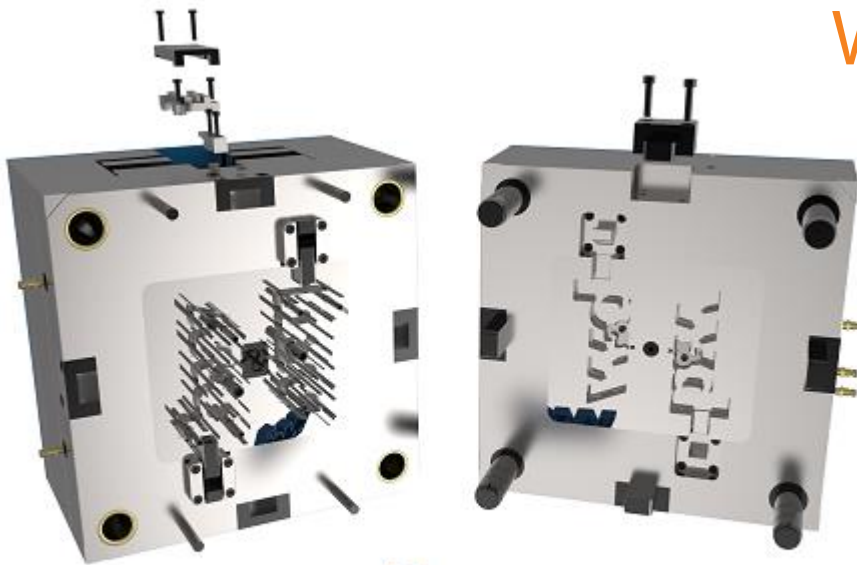

Enhancement

- Meusburger components updated to Status July 2023
- Diverse issues solved

EMX 15.0.3.4

What's New?

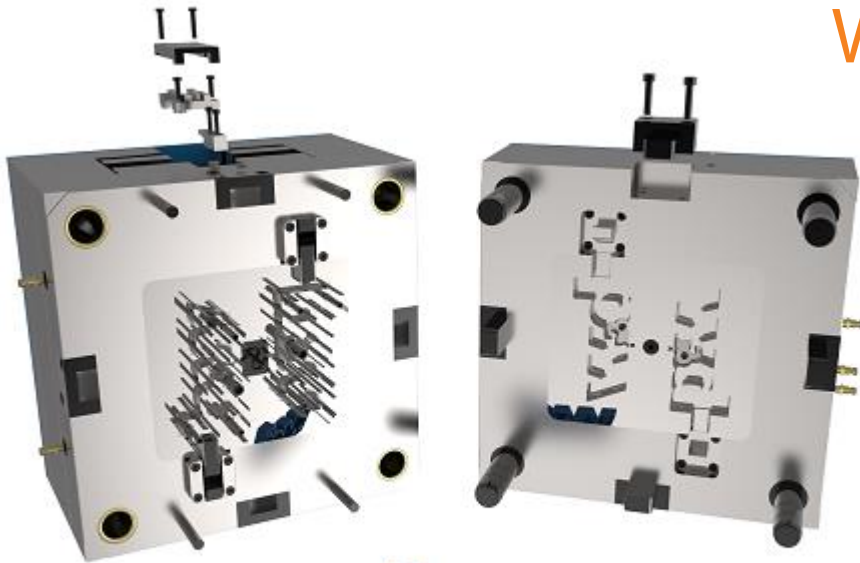

Enhancement

- New Component Type: **Electronic Components**
- **KNARR:** 807600, 807600-2, 807700, 807700-2, 807650, 808600, 808600-2, 808700, 808700-2, 808650, 807600-4, 808600-4
- **MEUSBURGER:** E6500, E65005, E6502, E65025, E6504, E6505, E65055, E6507, E65075, E6509
- **STRACK:** Z7600, Z7600-2, Z7600-4

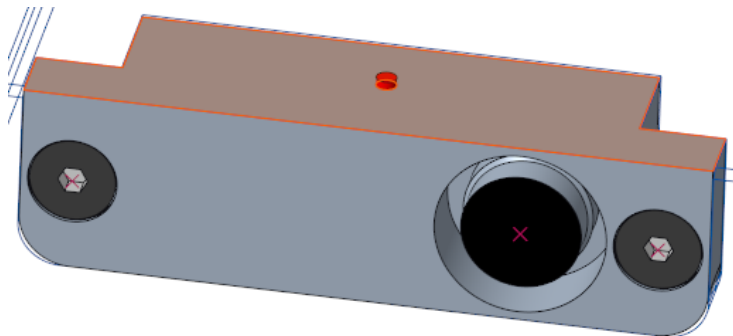
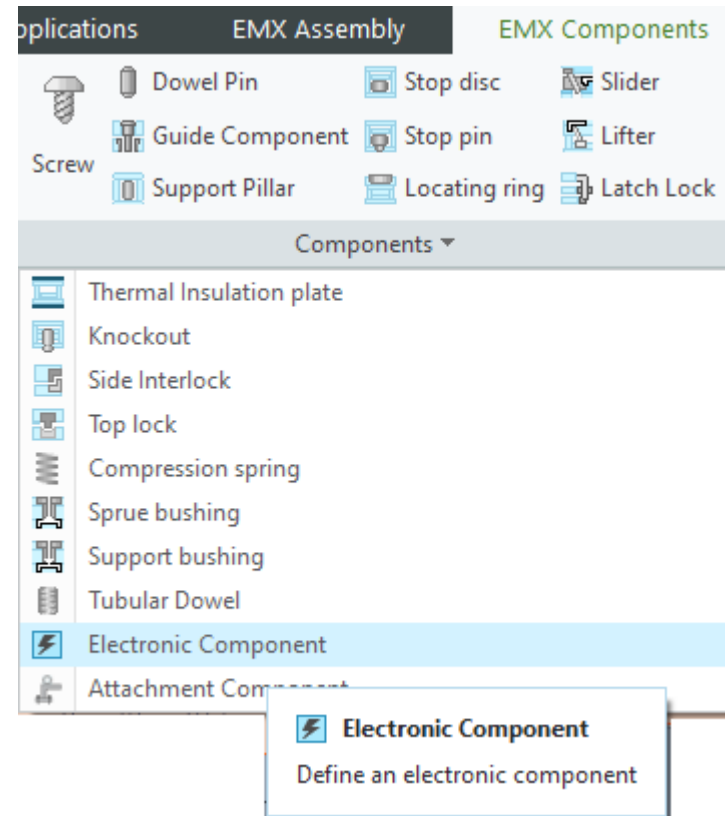

Enhancement

- New Component Type: **Attachment Components**
- **MEUSBURGER** limit switches:
E6500, E65005, E6502, E65025,
E6504, E6505
- **MEUSBURGER** transport bridge
E1930
- **OPTIZ** date stamps

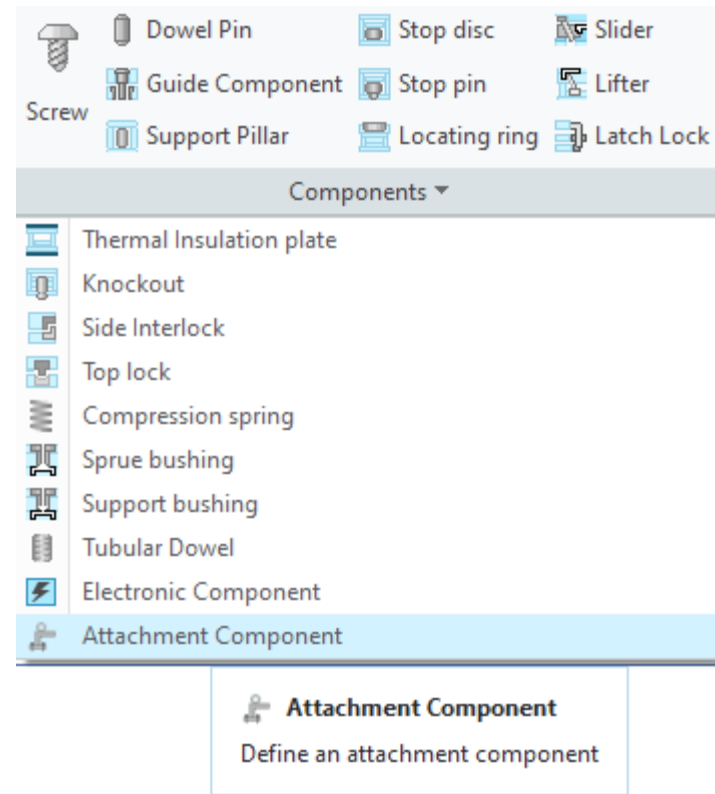
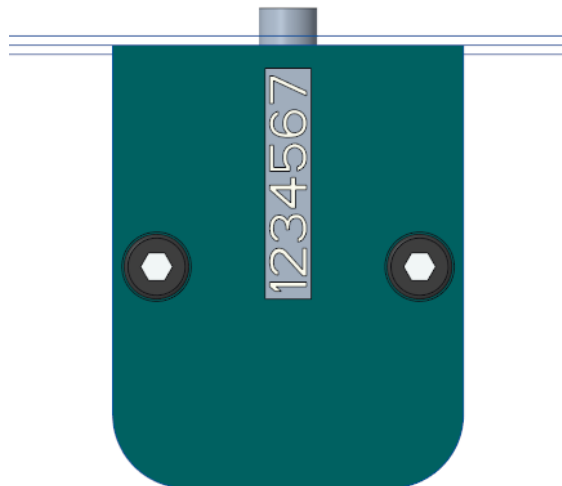

Enhancements

New components:

- New KNARR guide FreeLub 517404

EMX 15.0.3.1

What's New?

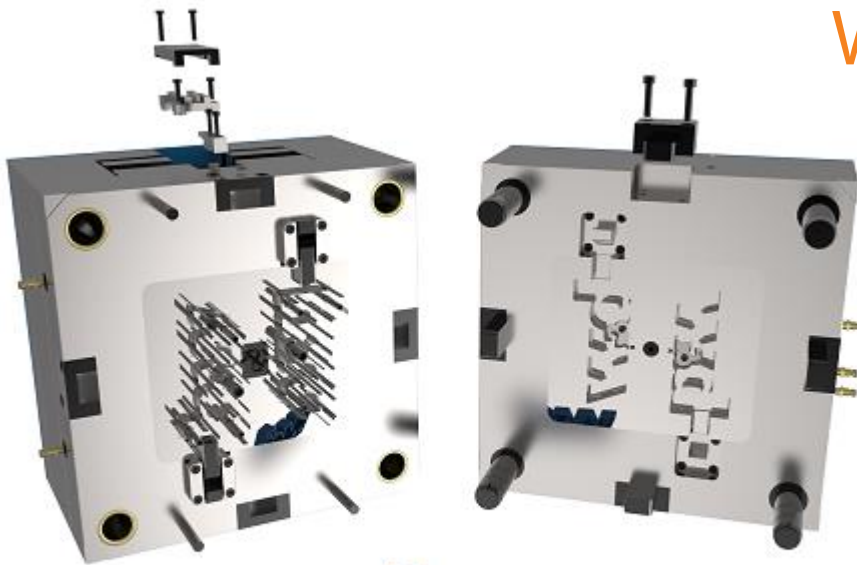

Enhancement

- New American Standard Sealing Rings for different assembly situations
- Components are assembled as flexible models.
 - Same model can be used in different assembly scenarios.
 - Model changes width based on compressed height without changing the volume of the sealing ring.
- Inner and outer pressure and coaxial scenarios are supported.

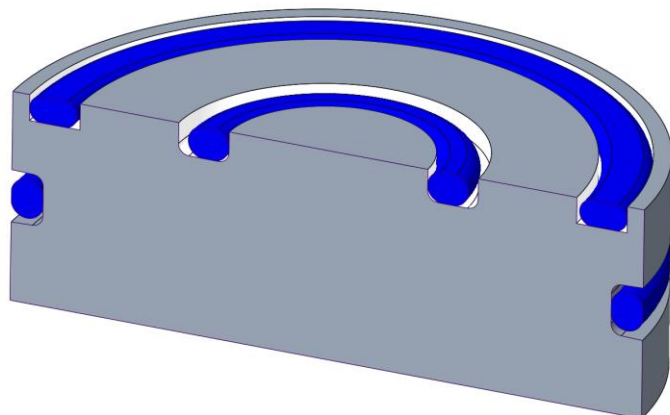

Cooling Component

Subassembly: 123

Unit: mm inch

Supplier: as

Type: AS568_AXIAL_FKM_75 | O-Ring

Dimension Name	Value	Type
DM2 - Diameter	1.78	
DM1 - Inner Diameter	1.78	
DM_FLEX - Mounting	5.287	
W_GROOVE - W_GROC	2.4	
T_GROOVE_FLEX - Gro	1.5	
DM_RESULT - Result Di	0.487	
OFFSET - Offset	0	

Part Name: 123_AS568_004_1_78_1_78

(1) Curve[Axis]Point (2) Surface

Component options: Circular Groove Add additional chamfers to edges

Draft Cut

Without Core Bore

Define depth by: Use curve length

Na:	Value	Tolerances	Rule
D5	1.000		1
T5	0.000		AUTO_DEPTH
D1	5.287		DM_FLEX
T1	1.500		T_GROOVE_FLEX
D3	0.487		DM_FLEX-2*W_GROOV
A	59.000		50
TX	3.000		T_GROOVE_FLEX*2

OK Cancel

Improvements

- Improved “Trim” feature behavior for ejector pins
 - Improved “Auto Length” feature behavior for ejector pins
- Auto length feature is now created as additional feature in ejector model.
 - “Real” length of ejector model is untouched.
 - In Modify mode “Auto Length” and “Trim” feature can be unset again.

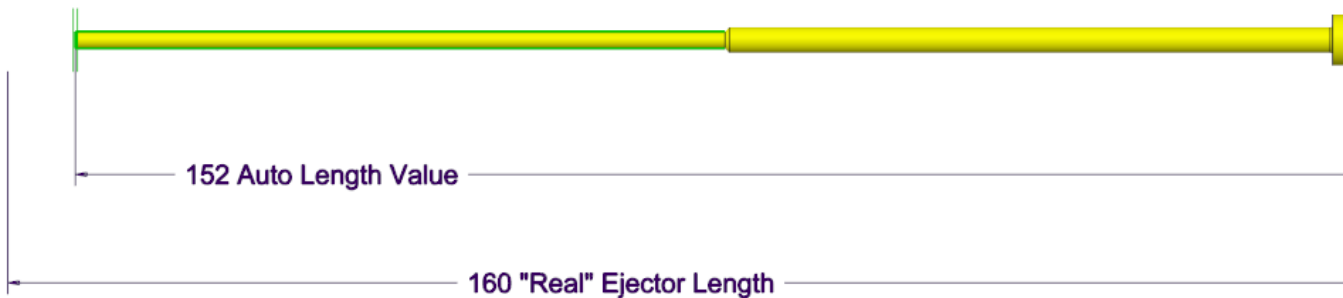
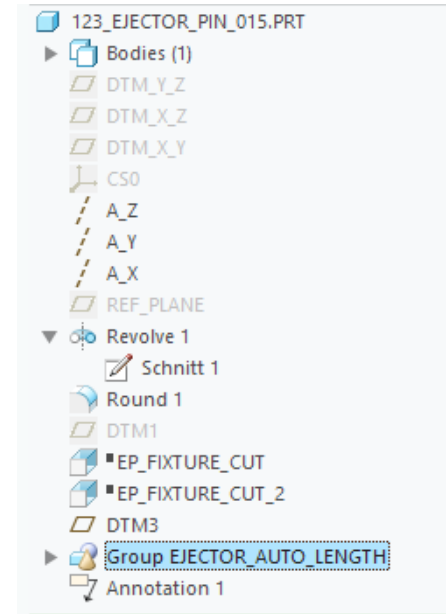

EMX 15.0.2.0

What's New?

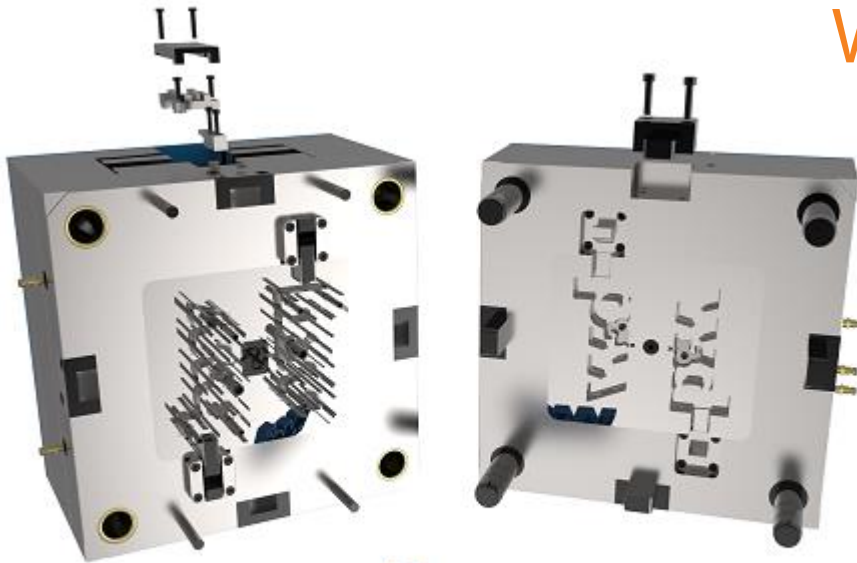

Improvements

- Add new Misumi guide components GPH and GPHL.

EMX 15.0.1.4

What's New?

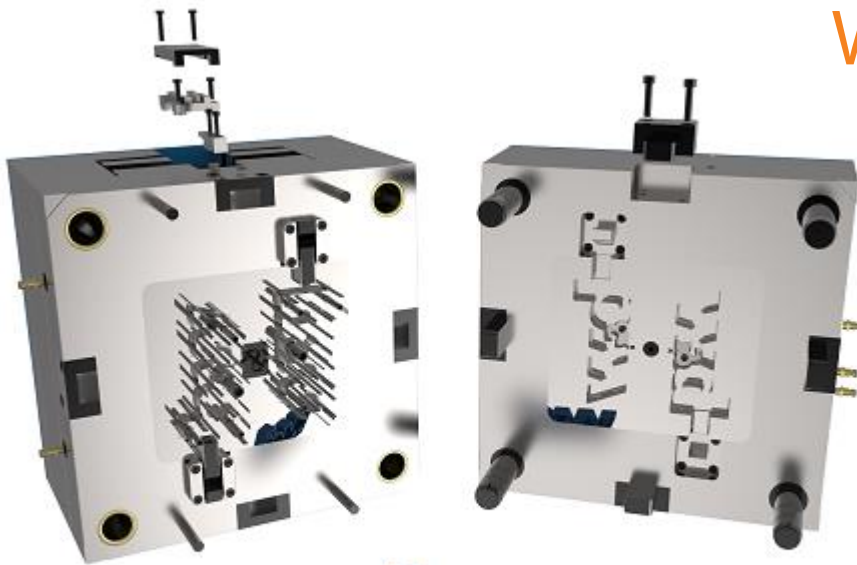

Improvements

- Improved Component Editor
 - Easily create part name rules for assemblies within dat files
 - Improved definition of instance dimensions with right mouse menu
 - etc.
- New config option EXCEL_TEMPALTE_PATH to set up default location for Bill of Material Excel template file

EMX 15.0.0.0

What's New?

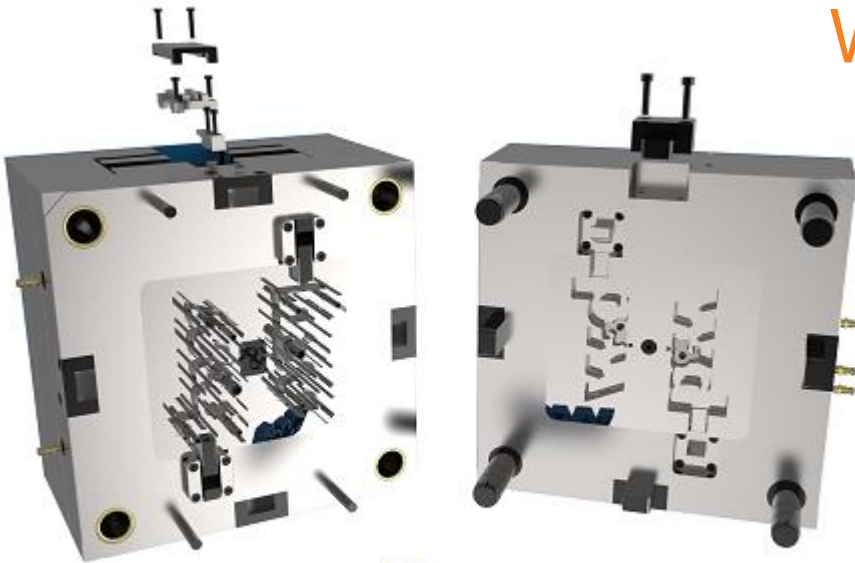

Enhancements

Compatible with new Creo 9.0.0.0