

# EMX 17.0.9.0

What's New?



# Enhancement

- New EMX Component Search  
 → New Search is available in **EMX Components Ribbon** → **Find**

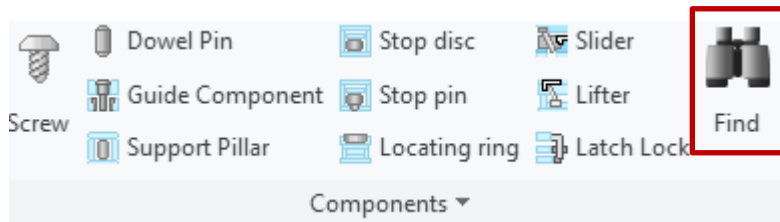

- Navigator contains:

## Search results:

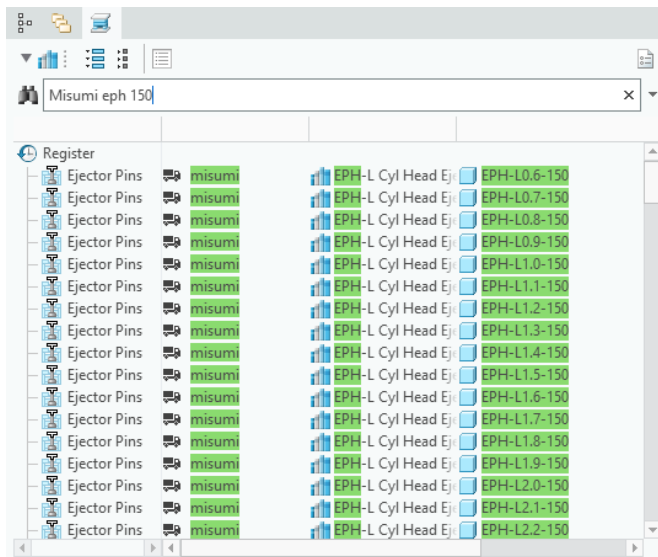

## Favorites:

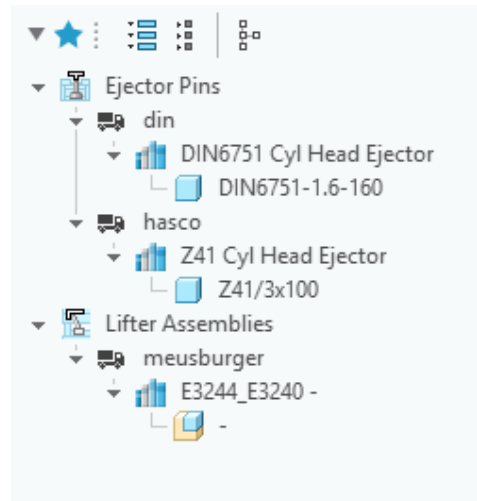

Favorites can also be added through Component Dialog

# Enhancement

---

- New Meusburger cooling components E20761 and E20762
- Update existing Meusburger components to state 6.2.15.0
- Update Smart Holechart to version 17.0.9.0
- Improved Bill of Material Excel export:
  - Allow Excel files with macros (\*.xlsm), templates (\*.xltx) and templates with macros (\*.xltm) for direct export from BOM.<br>
  - Option EXCEL\_TEMPLATE\_PATH may point to a specific template file, for example:  
"%EMX\_USER\_CONFIG\_PATH%configuration\bom-template.xlsm".
  - In this case export starts directly without showing a file browser. If necessary, option BOM\_FILENAME will be used to generate a new file name for the Excel export.

# EMX 17.0.8.1

What's New?

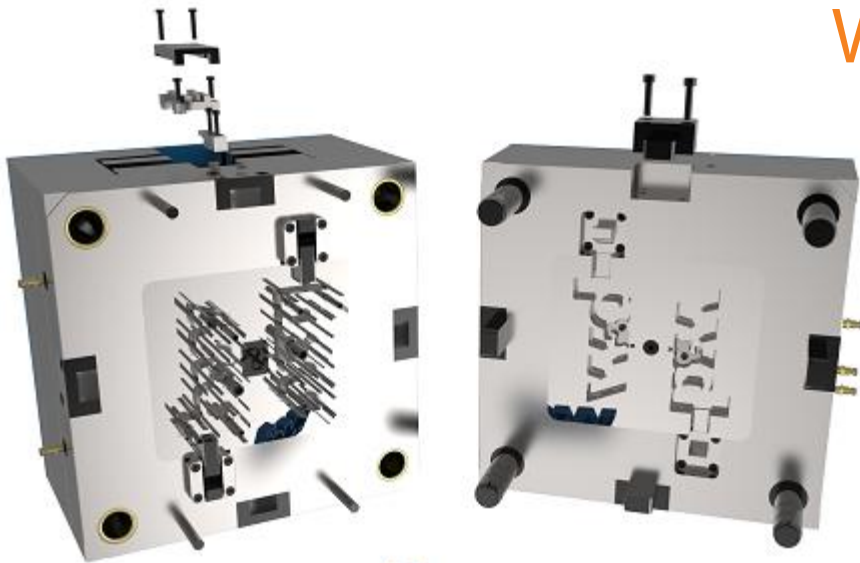

# Enhancement

---

- New Knarr ejector pins 326121, 326121 DLC
- Update Knarr plates to state 2025
- Introduce new parameter default type &project\_date to use the value defined in the project dialog

# EMX 17.0.8.0

What's New?

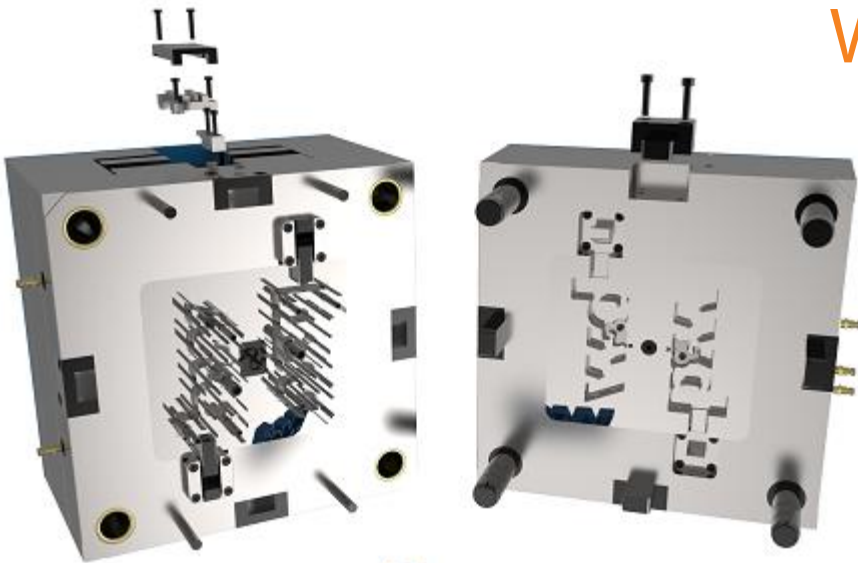

# Enhancement

---

- Predefined Components: Enable user to delete predefined auto screw and pin information from point.
- Component Editor Improvements:
  - Instance dimension can be added in case table cell is selected. It is not required to select column explicitly.
  - Part name rules: Side value can be selected from option menu.
  - Assembly references: Default reference value can be edited in table.
- Existing Meusburger components are updated to version 6.2.14.0 from November 2025.
- Meusburger web links support new Meusburger website.

# EMX 17.0.7.1

What's New?

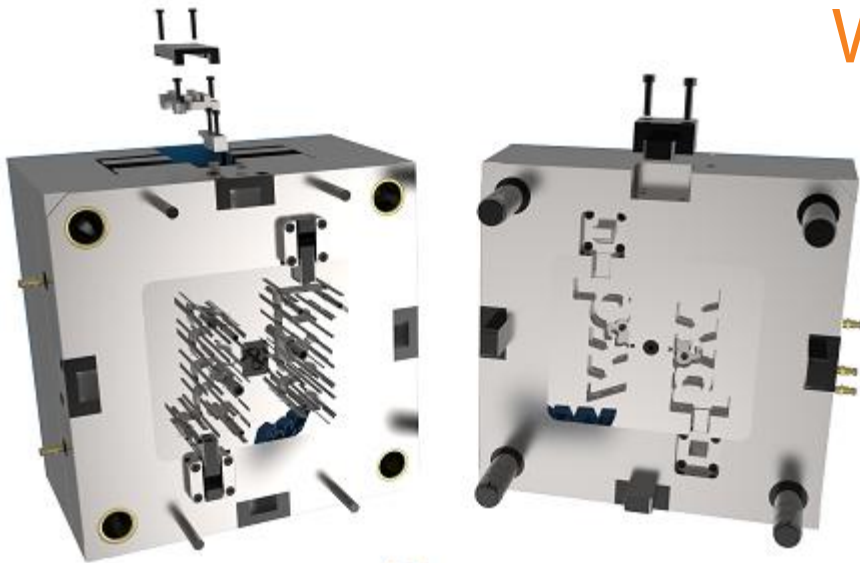

# Enhancement

- Component Handling: Implement solution to delete only one component in case it was assemble multiple times.
- Situation: In case a component as create multiple times with “Reassemble component” or defined on a multiple point feature
  - Previous behavior: All components are deleted always
  - New behavior: It is possible to deleted only the selected instance
    - Delete all? No! → Only selected instances

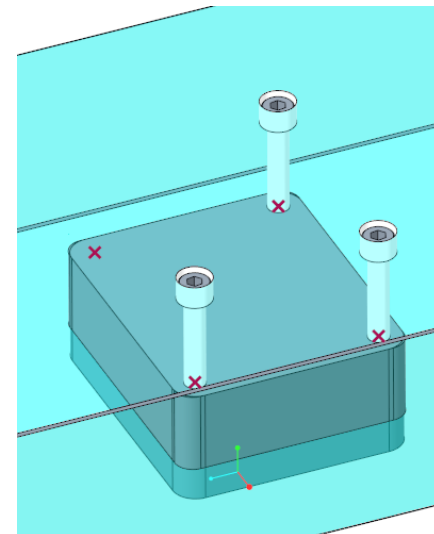
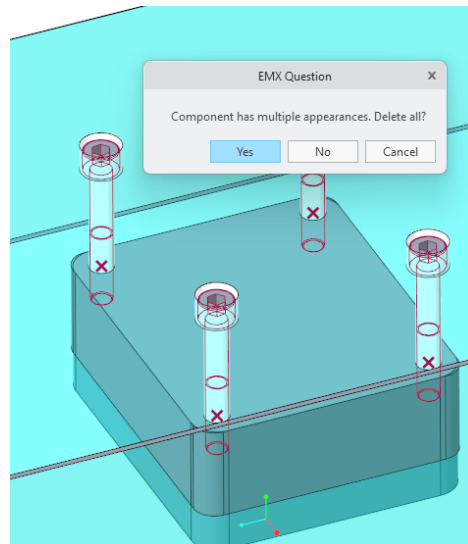
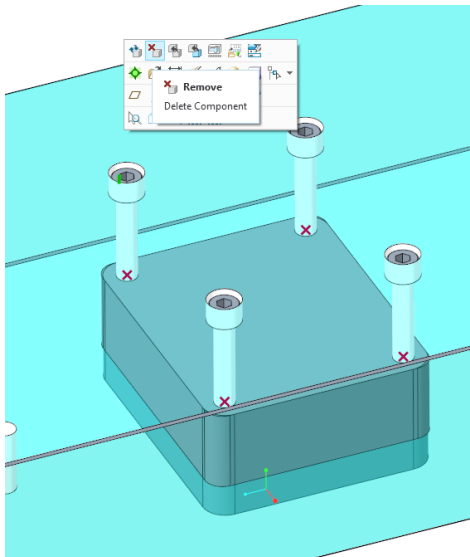

# EMX 17.0.7.0

What's New?

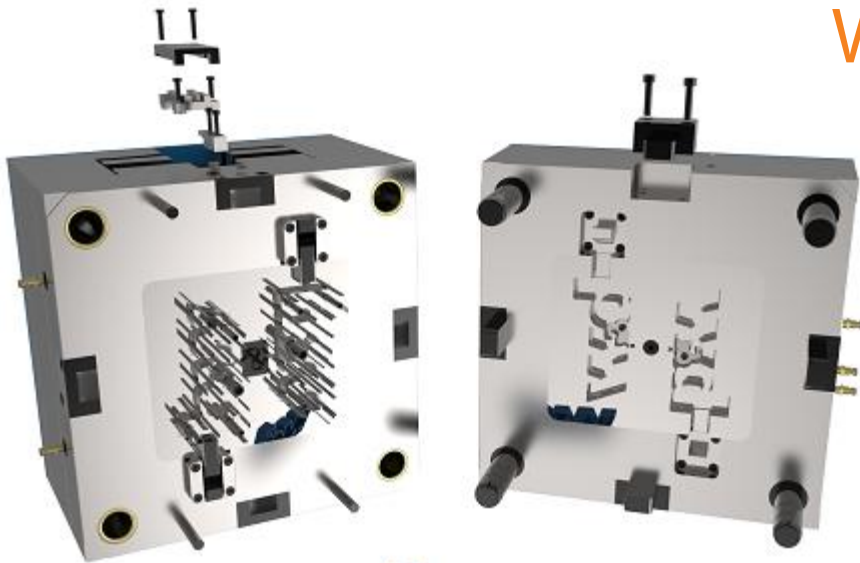

# Enhancement

- Component Dialog: Add right mouse button in nominal values and udf dimension table to set back manually edited values to default in edit fields and spin boxes.

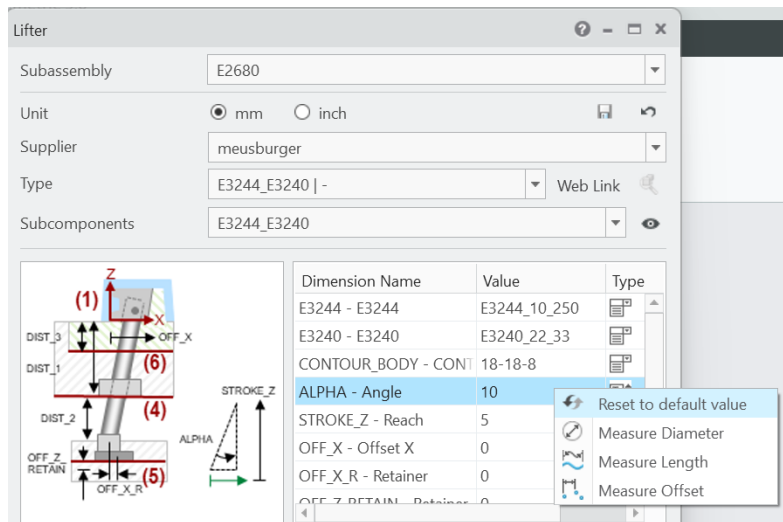

Nominal Value Table

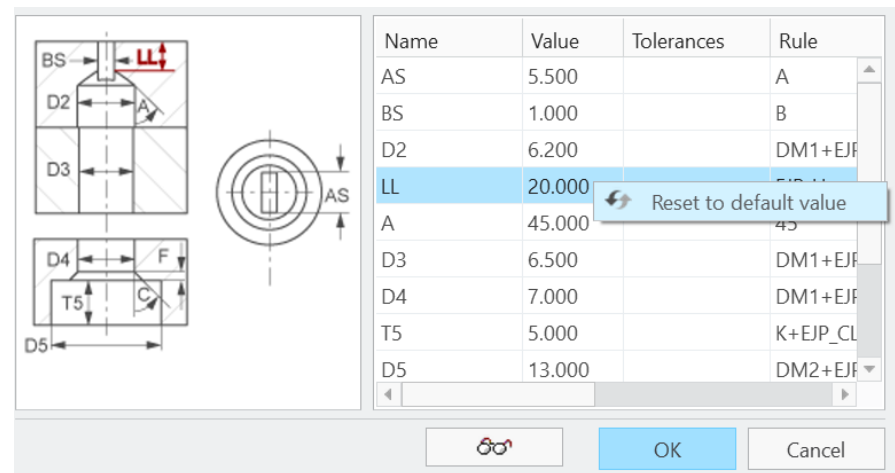

UDF Dimensions Table

# Enhancement

- Component Editor: Add additional push buttons to component editor besides buttons on right mouse menu to improve usability.
  - Right-Mouse buttons still exist.

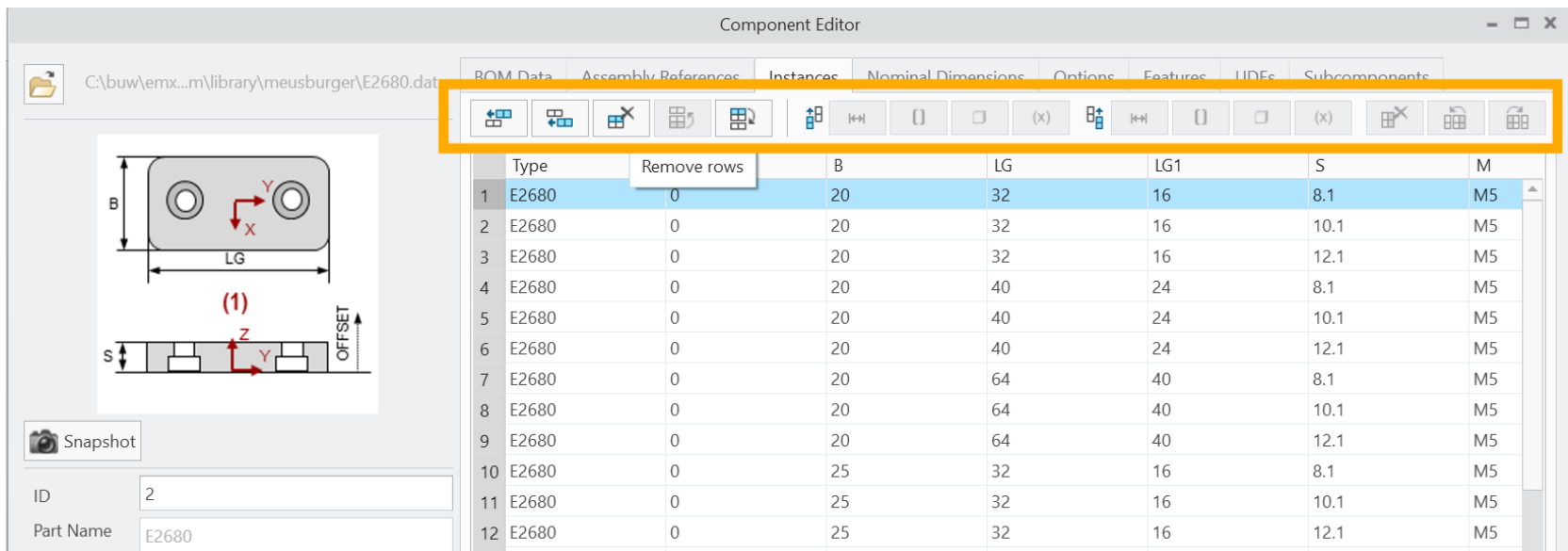

Type	Remove rows	B	LG	LG1	S	M
1 E2680	0	20	32	16	8.1	M5
2 E2680	0	20	32	16	10.1	M5
3 E2680	0	20	32	16	12.1	M5
4 E2680	0	20	40	24	8.1	M5
5 E2680	0	20	40	24	10.1	M5
6 E2680	0	20	40	24	12.1	M5
7 E2680	0	20	64	40	8.1	M5
8 E2680	0	20	64	40	10.1	M5
9 E2680	0	20	64	40	12.1	M5
10 E2680	0	25	32	16	8.1	M5
11 E2680	0	25	32	16	10.1	M5
12 E2680	0	25	32	16	12.1	M5

# Improvements

---

- Update existing Meusburger components to version 6.2.13.0
- Facelift for Wema and Ermanno Balzi cooling components.  
→ Improve images and models
- “Remove all Ejector Pins” should not delete the return pin.
- Component Editor: Cut quilt can be selected from feature in model tree and not only from model in graphic window.

# EMX 17.0.6.0

What's New?

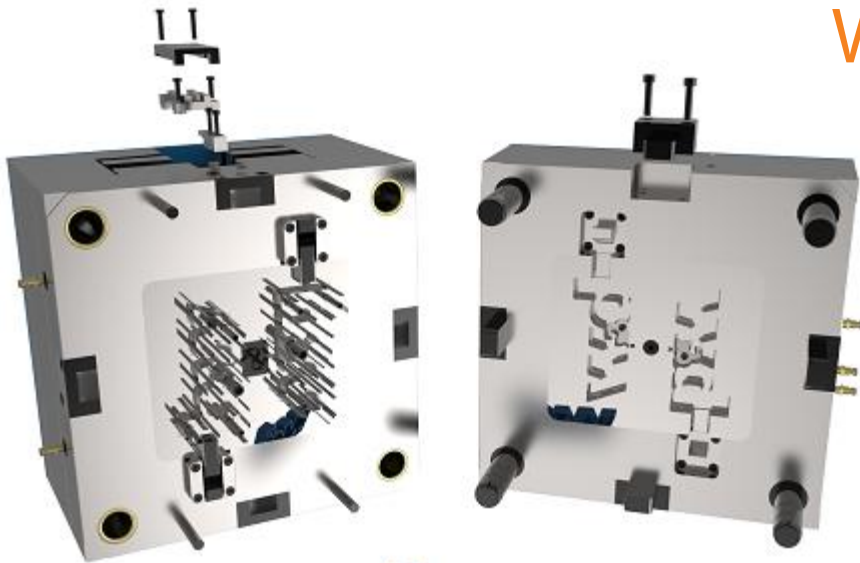

# Enhancement

---

- Configuration option EJP\_ENGRAVED\_TEXT\_SKETCH\_TYPE:  
Add additional selectable options to suppress the solid text cutout and only show curves:
  - a) `contour_curve_text_only`
  - b) `middleline_curve_text_only`
- Implement HASCO cooling components Z814, Z878, Z8190, Z8190HT, Z8190HT-VA
- Implement KNARR ejector pins with ventilation 300133, 300133 DLC, 300533, 300533
- Update SMARTHolechart to version 17.0.6.0

# EMX 17.0.5.0

What's New?

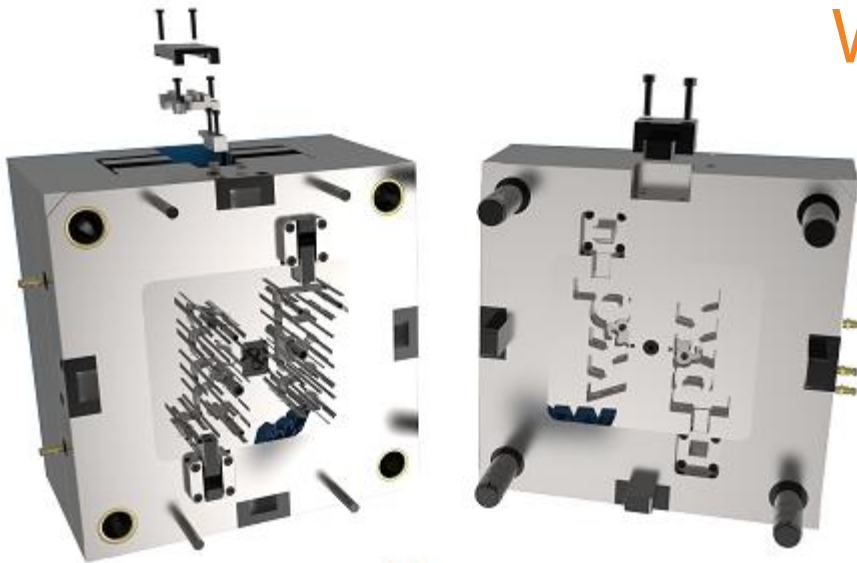

# Enhancement

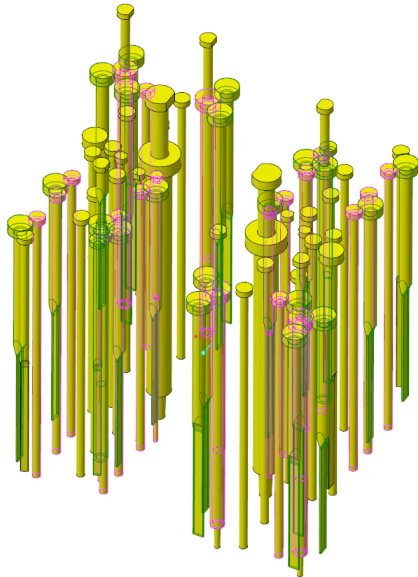
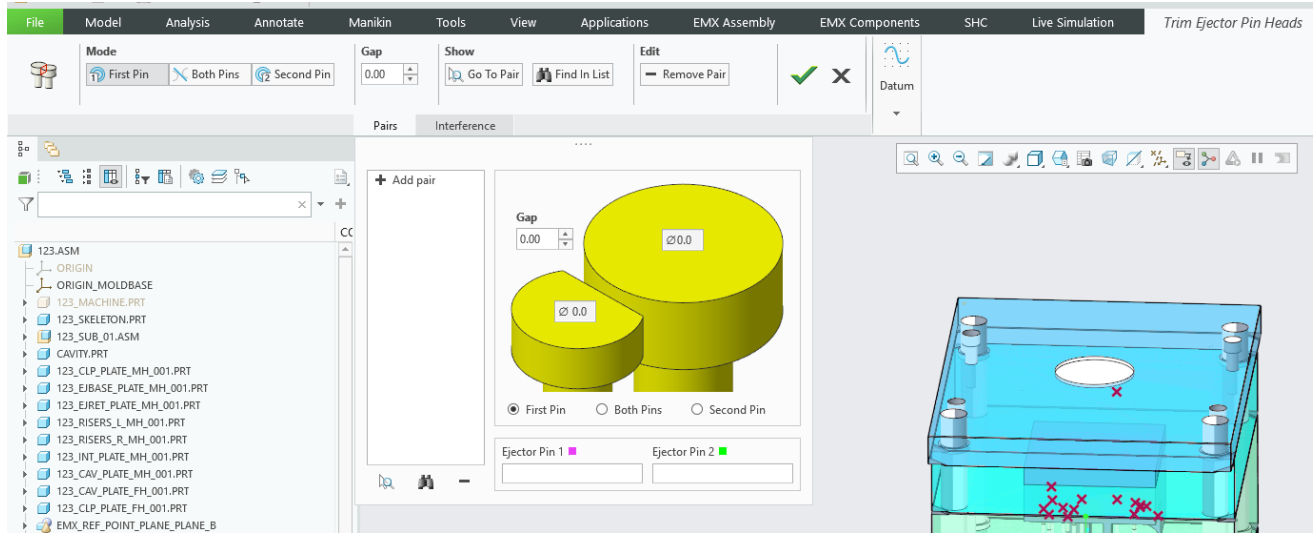

- Enhanced Trim Ejector Pin Heads capabilities
  - New Dashboard
  - Different trim shapes
  - Add and remove trim pairs
  - Manage existing pairs in list
  - Highlight pairs in 3D view

# Enhancement

---

- Library components and related cutouts can be considered in Extract Fluid circuits command, in case parameter BELONGS\_TO\_WATERLINE=„YES“ exists at model.
  - New Meusburger cooling components E2016, E20169, E20259, E2020HT, E2020 D and E20209HT
  - Update all existing Meusburger components to state 6.2.11.0
  - Improve performance of Excel export
  - Update SmartHolechart to Version 17.0.5.0
- 
- Decorative curved lines in the bottom right corner, consisting of a thick grey curve and a thin orange curve.

# EMX 17.0.4.0

What's New?

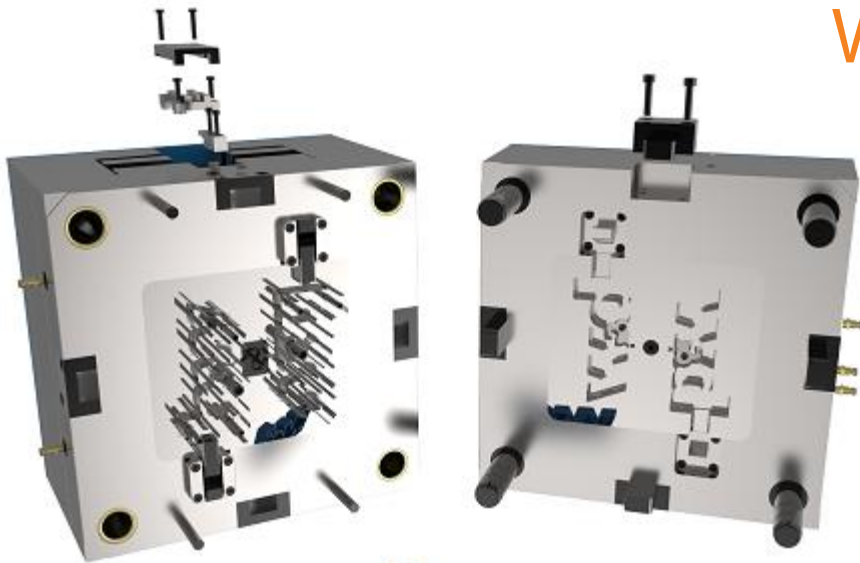

# Enhancement

- Improve the Extract fluid circuit functionality
  1. Improve algorithm to detect related fluid bores
  2. Implement new radio group with option to assemble a subassembly for fixed and moving half, but also a part for each cooling circuit
  3. Use progress bar to avoid freezing of Creo window

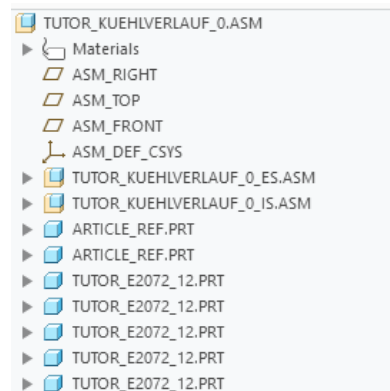
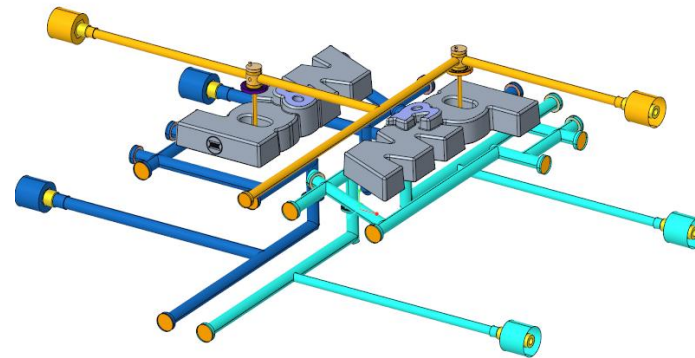
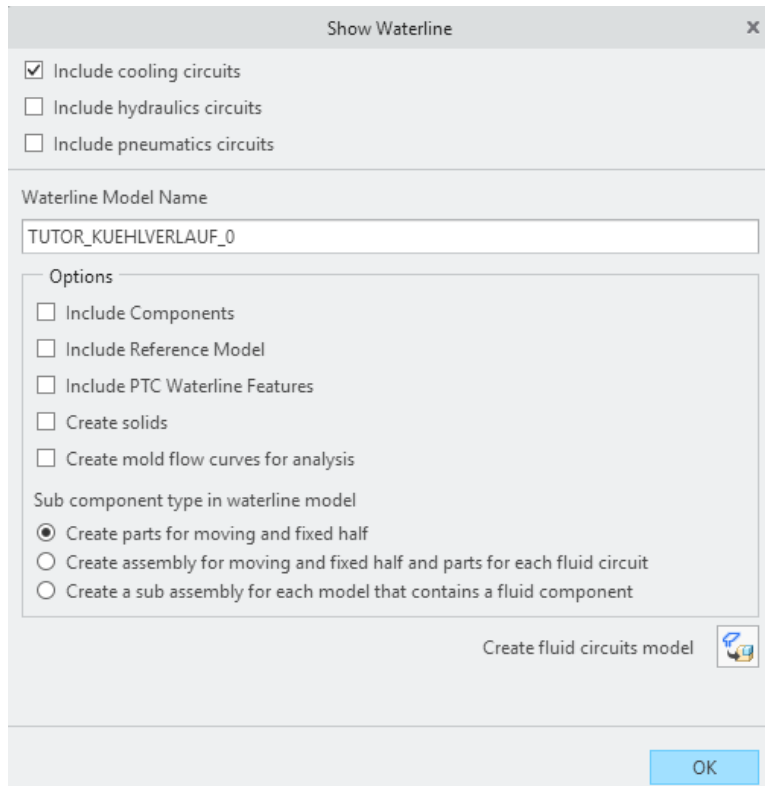

# Enhancement

- Implement solution to directly use measured values from Tiny Measure Tools in nominal values of component dialog
  1. Select dimension in nominal values table
  2. Open Tiny Measure Tools with Right Mouse Click
  3. Measure diameter, length or offset
  4. Best fit value will be used in nominal value table

The diagram illustrates the workflow for the enhancement. It starts with a 3D model of a shaft with a diameter dimension (DM1) and a length dimension (LG). A context menu is shown over the dimension table, with 'Measure Diameter' selected. An 'EMX Question' dialog box appears, displaying the measured diameter (4.500) and the best fit value (4.5), asking if the best fit result should be used in the nominal value. Finally, the dimension table is updated with the measured value of 4.5.

Dimension Name	Value	Type
DM1 - Diameter	0.4	
LG - Length	100	
OFFSET - Offset	0	
REF_ANGLE - Angle	0	
REF1 - Reference Dista	56.000	

Dimension Name	Value	Type
DM1 - Diameter	4.5	
LG - Length	100	
OFFSET - Offset	0	
REF_ANGLE - Angle	0	
REF1 - Reference Dista	56.000	

# Enhancement

---

- Update SmartHolechart to Version 17.0.4.0
- New Components Meusburger Guide E1332 and E1146
- Implement new cooling O-rings from new suppliers Hagenauer and Arcus
- Add Ermanno Balzi cooling component TR, TRI, RF, RFP, RL, RLS

# EMX 17.0.3.1

What's New?

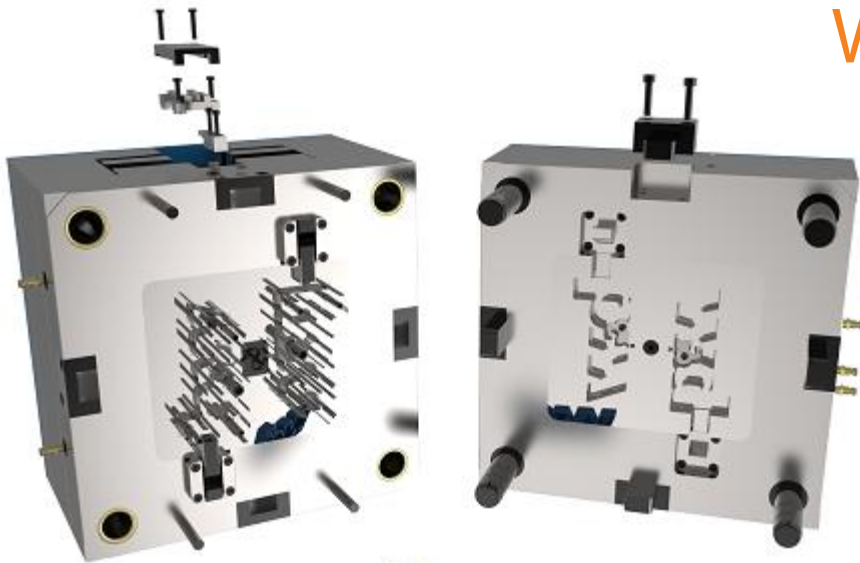

# Enhancement

---

New HASCO cooling components:

- Z87: Hose Nipple
- Z87VA: Hose Nipple, stainless steel
- Z9425: Sealing plug with O-Ring
- Z9425VA: Sealing plug with O-Ring, stainless steel
- ZI81: Hose Nipple, Open Flow, USA

# Enhancement

---

- Implement new config option BOM\_ALLOW\_EDIT\_PROJECT\_PARAMS to allow manual editing of project parameters in BOM

Default Value is: NO

Behavior NO:

- Project parameters are disabled in Bill of Materials List.
- Value can not be edited
- Value is always overwritten from top assembly

Behavior YES:

- Project parameter can be edited in Bill of Materials
  - Value needs to be unlocked in BOM
- 
- Decorative curved lines in the bottom right corner, consisting of a thick grey arc and a thin orange arc.

# EMX 17.0.3.0

What's New?

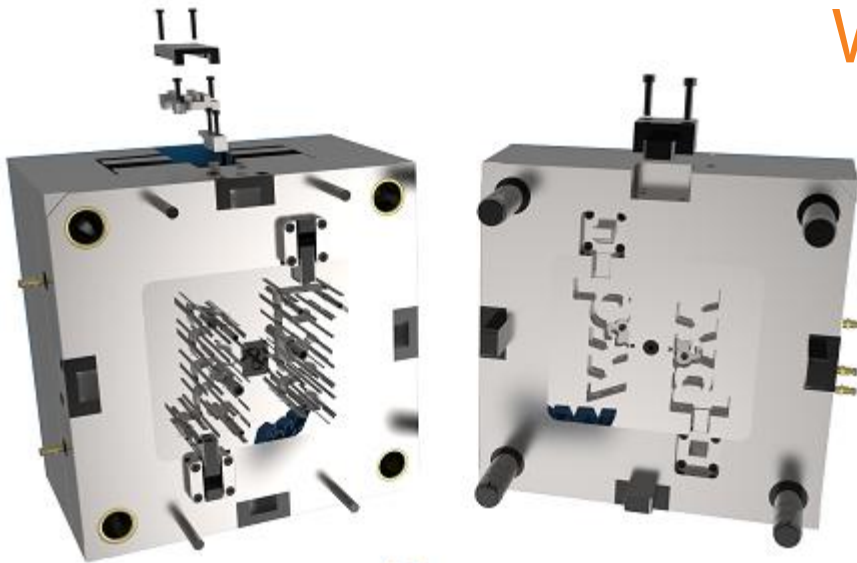

# Enhancement

- Introduce functionality to save configuration to current session only. “Current Session” can be selected in Options Dialog from option menu

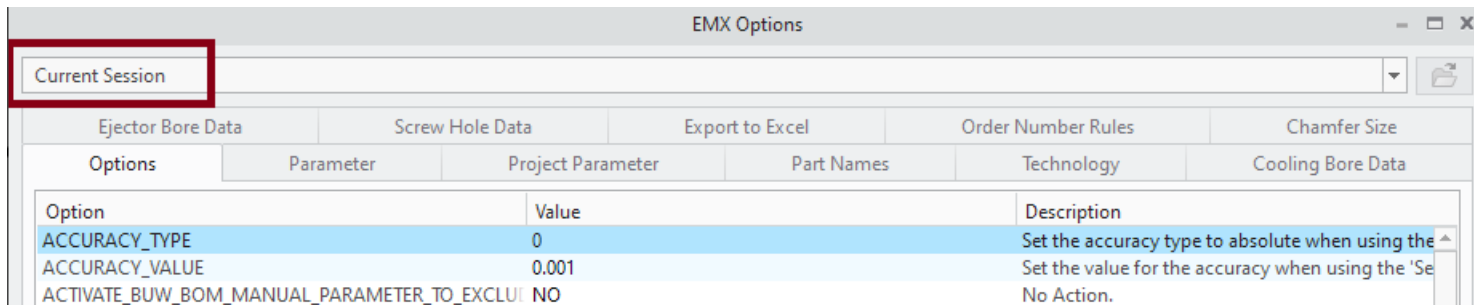

- Several minor fixes and internal improvements

# EMX 17.0.2.3

What's New?

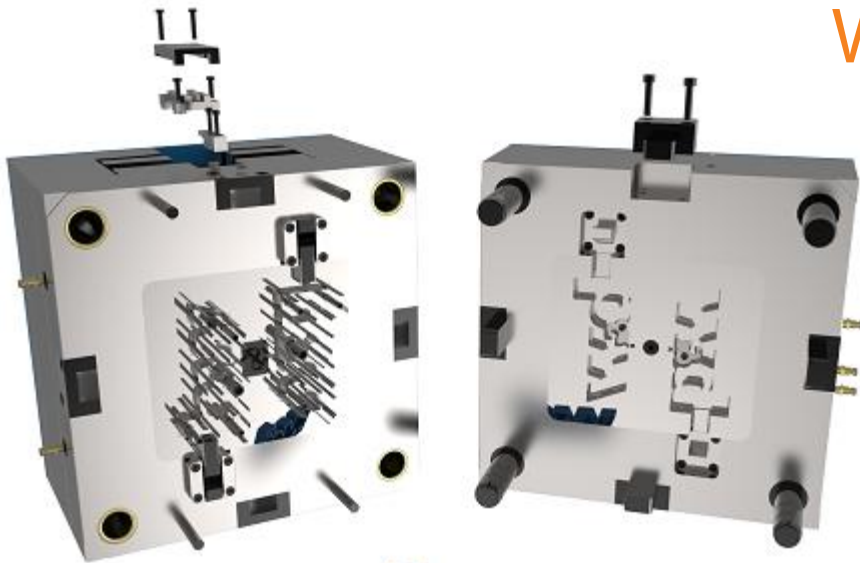

# Enhancement

---

- Update Smart Holechart to Version 17.0.2.1
- Allow flexible items for guide components
- Several minor fixes and internal improvements

# EMX 17.0.2.1

What's New?

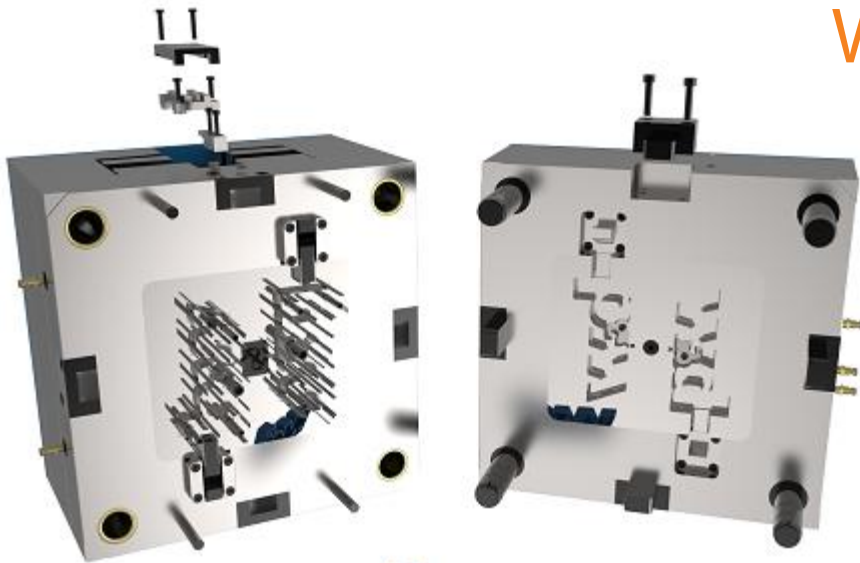

# Enhancement

---

- Several fixes
- Update SmartHolechart to Version 17.0.2.0

# EMX 17.0.1.1

What's New?

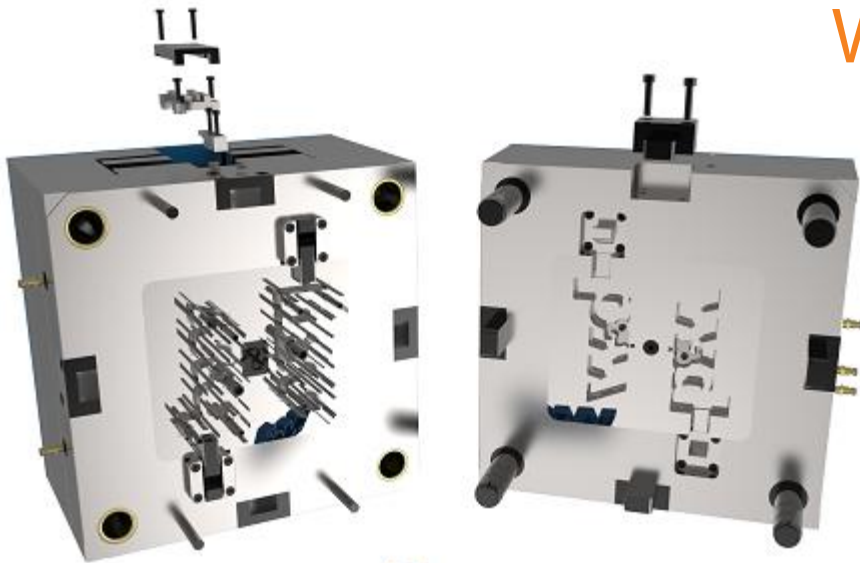

# Enhancement

---

- Update existing MEUSBURGER components to state April 2024
- Enhancements for Engraved Texts for ejector pins:
  - New Options EJP\_ENGRAVED\_TEXT\_TYPE: Sketch can be created as contour or middle line.
  - Parameter defined in PARAM\_EJP\_ENGRAVED\_TEXT will only be created at ejector pin models.

# EMX 17.0.0.1

What's New?

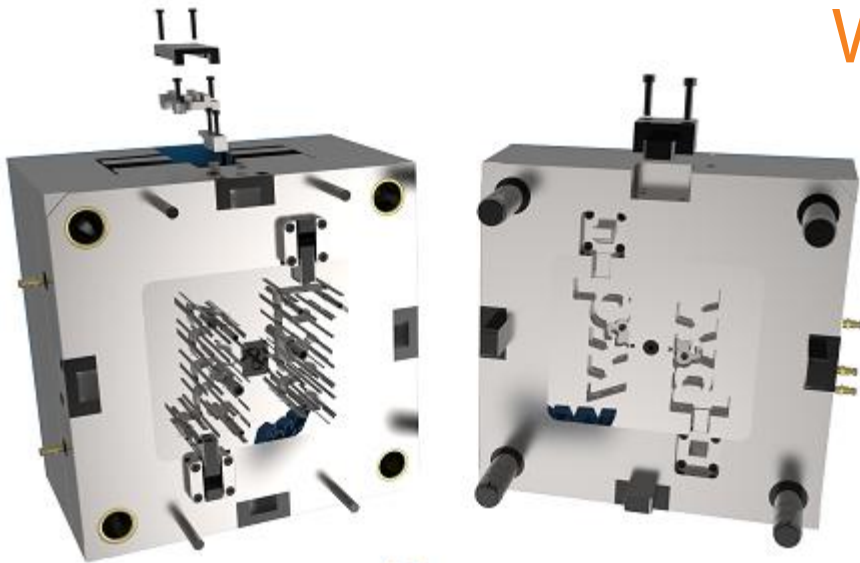

# Enhancement

## New Feature: Assemble engraved texts for Ejector Pins

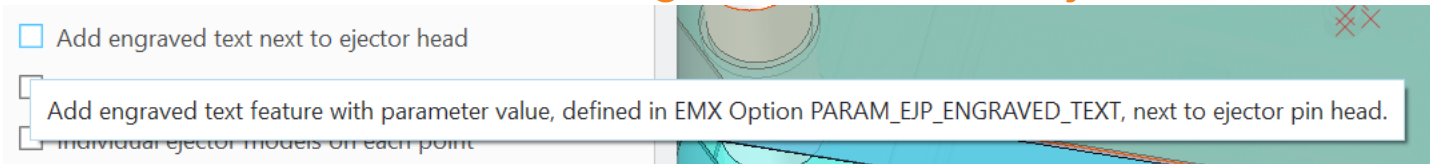

- New Option in Ejector Dialog: *Add engraved text next to ejector head*
- Text feature will be created in ejector model on head surface and next to head cutout UDF in plate.
- Text is controlled by relation and driven by a part parameter
- Part parameter must be defined with new Configuration Option *PARAM\_EJP\_ENGRAVED\_TEXT* otherwise option in ejector dialog is disabled.
- New config file: *engraved\_text\_heights.cfg* to define valid text heights



# Enhancement

---

- Update existing HASCO components to state April 2024
- Update existing KNARR components to state April 2024
- Improve performance of additional chamfer creation in case of multiple point features.

# EMX 17.0.0.0

What's New?

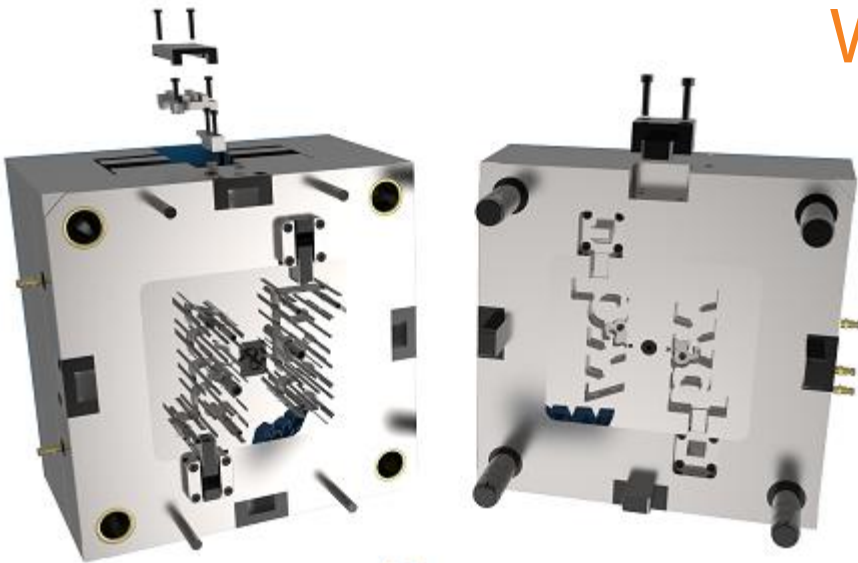

# Enhancement

---

- EMX ready for Creo 11.0.0.0