

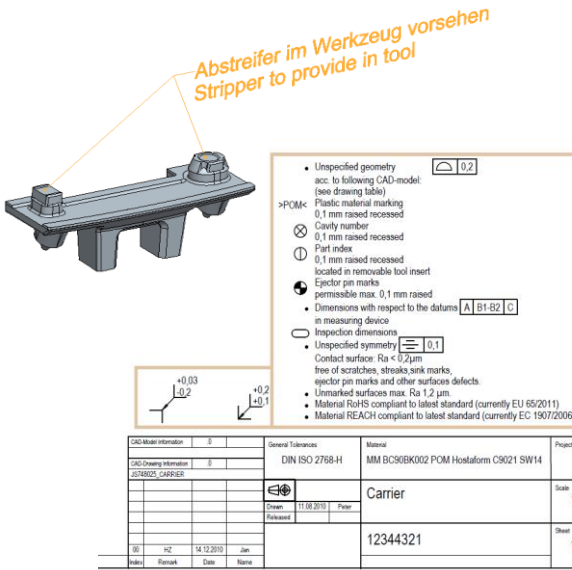

SMARTAnnotate



Select, place and manage
Standard Annotations
 in your
3D Model and 2D Drawing
SMART – FAST – ROBUST
 Integrated in
creo® parametric

You like to ...

- ... quickly select and place annotations, symbols and tables from a database.
- ... simplify and harmonize the management of your standard annotations.
- ... switch your text notes automatically to a different language.
- ... flexibly manage your meta data and drawing formats.

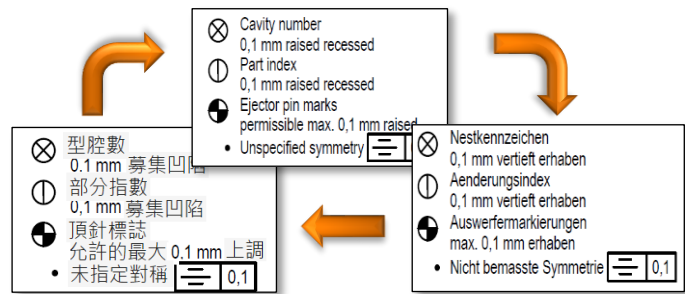

SMARTAnnotate offers:

- An intuitive dialog for placing standard annotations from a custom database
- Intelligent and highly customizable filter mechanism for the annotations
- Automatic and manual placement of annotations in drawings and models
- Automatic switch of text notes to another prepared language
- Easy and flexible management of annotation elements, meta data and drawing formats

